

P-51D Mustang User Manual

Wingspan: 1600mm

Length: 1420mm

Empty Weight: 3270G[w/o Battery]

www.freewing-model.com



www.freewing-model.com



1	Introduction	16	前言
2	Product Basic Information	17	产品规格参数
2	Package list	17	包装列表
3	PNP Assembly Instructions	18	PNP组装步骤介绍
3	Install Propeller	18	螺旋桨组装
4	Install the Horizontal tail and Vertical tail	19	平尾、垂尾组装
5	Install Main Wing	20	主翼组装
6	Install other accessories	21	其他配件组装
7	Install the drop tanks	22	油箱组装
8	Usage of FPV cabin wood piece	23	FPV座舱木片使用方法
9	Pushrod Instructions	24	舵面控制钢丝尺寸及安装孔位
10	Control Board Introduction	25	集线控制板介绍
11	Battery Instructions	26	电池介绍
12	Center of gravity	27	重心示意图
13	Control Direction Test	28	模型舵面测试
14	Dual Rates	29	舵量范围
15	Servo Direction	30	舵机介绍
15	Motor Specification	30	电机介绍

Note:

- 1.This is not a toy! Operator should have a certain experience, beginners should operate under the guidance of professional players.
- 2.Before install, please read through the instructions carefully and operate strictly under instructions.
- 3.Cause of wrong operation, Freewing and its vendors will not be held responsible for any losses.
- 4.Model planes' players must be on the age of 14 years old.
- 5.This plane used the EPO material with surface spray paint, don't use chemical to clean, otherwise it will damage.
- 6.You should be careful to avoid flying in areas such as public places, high-voltage-intensive areas, near the highway, near the airport or any other place where laws and regulation clearly prohibit.
- 7.You cannot fly in bad weather conditions such as thunderstorms, snows....
- 8.Model plane's battery, don't allowed to put in everywhere. Storage must ensure that there is no inflammable and explosive materials in the round of 2M range.
- 9.Damaged or scrap battery should be properly recycled, it can't discard to avoid spontaneous combustion and fire.
- 10.In flying field, the waste after flying should be properly handled, it can't be abandoned or burned.
- 11.In any case, you must ensure that the throttle is in the low position and transmitter switch on, then it can connect the lipo-battery in aircraft.
- 12.Do not try to take planes by hand when flying or slow landing process. You must wait for landing stop, then carry it.

⚠ NOTE: This is not a toy. Not for children under 14 years. Young people under the age of 14 should only be permitted to operate this model under the instruction and supervision of an adult. Please keep these instructions for further reference after completing model assembly.

Thank you for purchasing the FlightLine RC WWII series model plane P-51. When you assemble and use this model airplane, please carefully read the instructions and follow the instructions to assemble and debug the product. During this process, if any problems are found, please contact the seller immediately or contact us directly, we will provide you with all necessary assistance!

FlightLine P-51D "Mustang" model plane replicates the classic silhouette of the legendary World War II fighter jet, designed in a 1/7 scale, with a wingspan of 1600mm and a length of 1420mm. The large size specification balances visual impact and handling stability, making it highly expressive for both static display and dynamic flight. The livery of this model aircraft is based on the vehicle of Major Thomas L. Hayes from the 364th Fighter Squadron of the 357th Fighter Squadron during the Normandy landings in World War II. The main color is olive green, and the bottom is neutral gray. The main wing, fuselage, and horizontal tail have black and white stripes or white invasion stripes make the model have excellent attitude recognition in the air.

Numerous mature and excellent structural designs are applied to the FlightLine P-51D "Mustang" model plane, enhancing product performance and user experience in multiple dimensions.

The P-51D "Mustang" adopts a high lift to drag ratio wing structure design, and the power system is equipped with a 5055 brushless out-runner motor, compatible with 6S batteries. This aircraft model performs outstandingly in short takeoff performance, with strong short-range explosive power and a short ground clearance distance (<15 meters). The main wheel with a diameter of 95mm enables it to adapt to various takeoff and landing environments.

In terms of flight speed, the maximum cruising speed is about 150 kilometers per hour (KPH); At the same time, under the condition of only outputting about 25% throttle, low-speed cruising at 80 kilometers per hour (KPH) can be achieved, with stable power output and excellent energy consumption control in low-speed cruising state. In terms of endurance, when equipped with a 6S 5000mAh battery, the maximum endurance time can reach 6 minutes (of which 60% is full throttle flight time), which can meet the needs of long-term flight.

Maneuverability is one of the core advantages of P-51D, with a minimum turning radius of less than 10 meters during horizontal maneuvering and flexible steering. The vertical climbing phase has strong power output and can maintain a stable climbing state for a long time. With excellent aerodynamic design and power matching, this model can easily complete classic stunt actions such as "wingover", without the risk of stall during flight, and has both operational safety and stability.

During the landing phase, lowering the flaps can further reduce the safe flight speed. At low speeds, the stability matches the response of the control surface, and the control accuracy is excellent. The landing gear has excellent shock absorption and energy absorption effects, making it less prone to bouncing during landing and ensuring smooth takeoff and landing. In addition, in response to the unique anti twist characteristics of propeller aircraft, this model has been specially designed and optimized, significantly reducing the phenomenon of tail shaking during takeoff and landing, effectively reducing the risk of yaw and rollover, and further improving takeoff and landing safety.

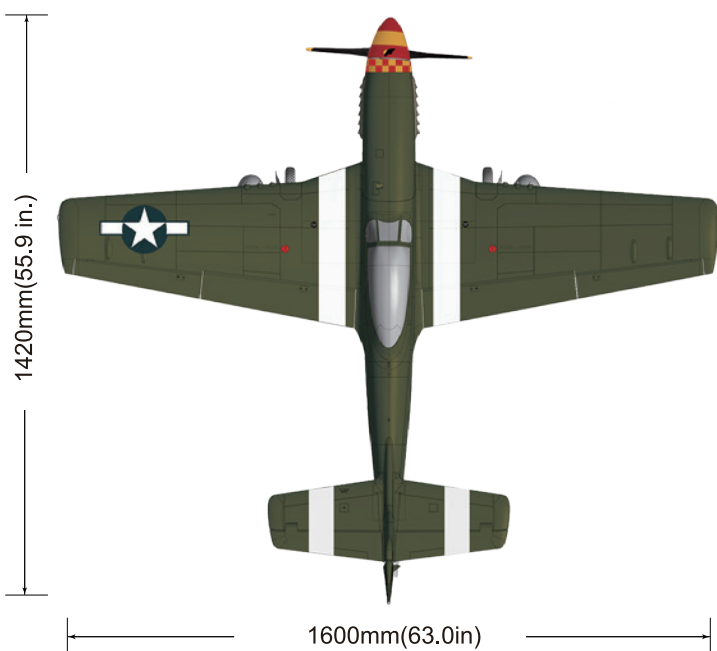

Standard Version

Wingload: 89g/dm²
 Wing Area: 46dm²
 Servo: 9g Digital plastic servo (3pcs)
 9g Hybrid digital servo (1pcs)
 9g MG digital servo(2pcs)
 17g MG digital servo(5pcs)
 23g MG digital servo(1pcs)
 Motor: 5055-390KV O/R Motor
 Propeller: 16x12 4-Blade
 ESC: 80A Brushless ESC
 Weight: 3270g(w/o Battery w/o drop tank)

Other Notes

Landing gear: Electric landing gear
 Li-Po Battery: 6S 5000-6000mAh
 Cabin doors: front and rear complete cabin doors
 Other: LED navigation lights, Gun Light

⚠ Note: The parameters in here are derived from test result using our accessories. If use other accessories, the test result will be different. Any problem since of using other accessories, we are not able to provide technical support.

Package List

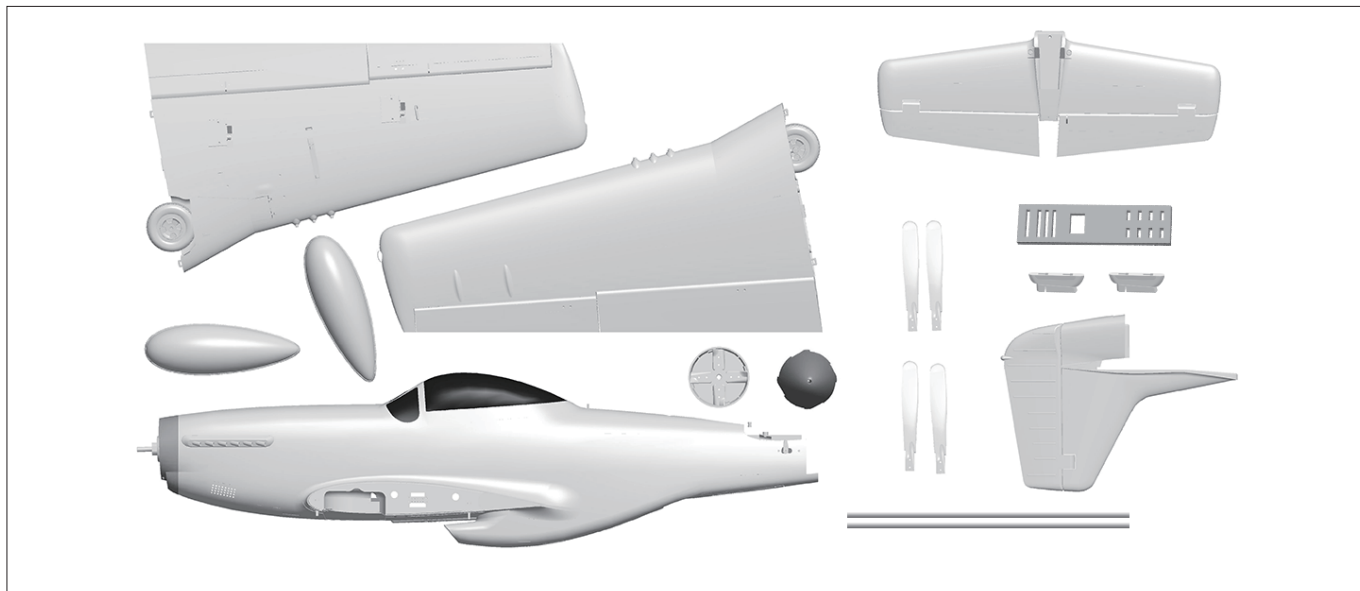

Different equipment include different spareparts. Please refer to the following contents to check your sparepart list.

No.	Name	PNP	ARF Plus
1	Fuselage	Pre-installed all electronic parts	Pre-installed servo
2	Main wing	Pre-installed all electronic parts	Pre-installed servo
3	Vertical tail	Pre-installed all electronic parts	Pre-installed servo
4	Horizontal tail	Pre-installed all electronic parts	Pre-installed servo
5	Drop tank	✓	✓

No.	Name	PNP	ARF Plus
6	Carbon tube	✓	✓
7	Propeller	✓	✓
8	Annex bag	✓	✓
9	Manual	✓	✓

Install Propeller

- A- Screw (M3*14mm 8PCS)
- B- Propeller clip reinforcement plate (1PCS)
- C- Propeller (4PCS)
- D- Propeller fixing plate (1PCS)

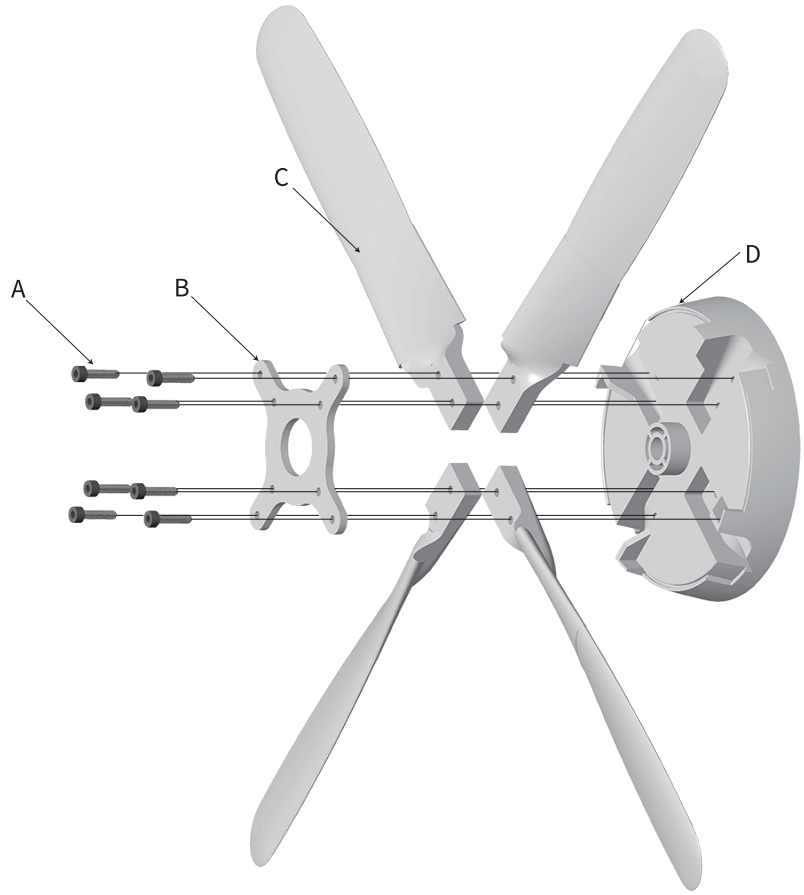

- A- Screw (M3*7mm 1PCS)
- B- Spinner (1PCS)
- C- Propeller clip nut (1PCS)

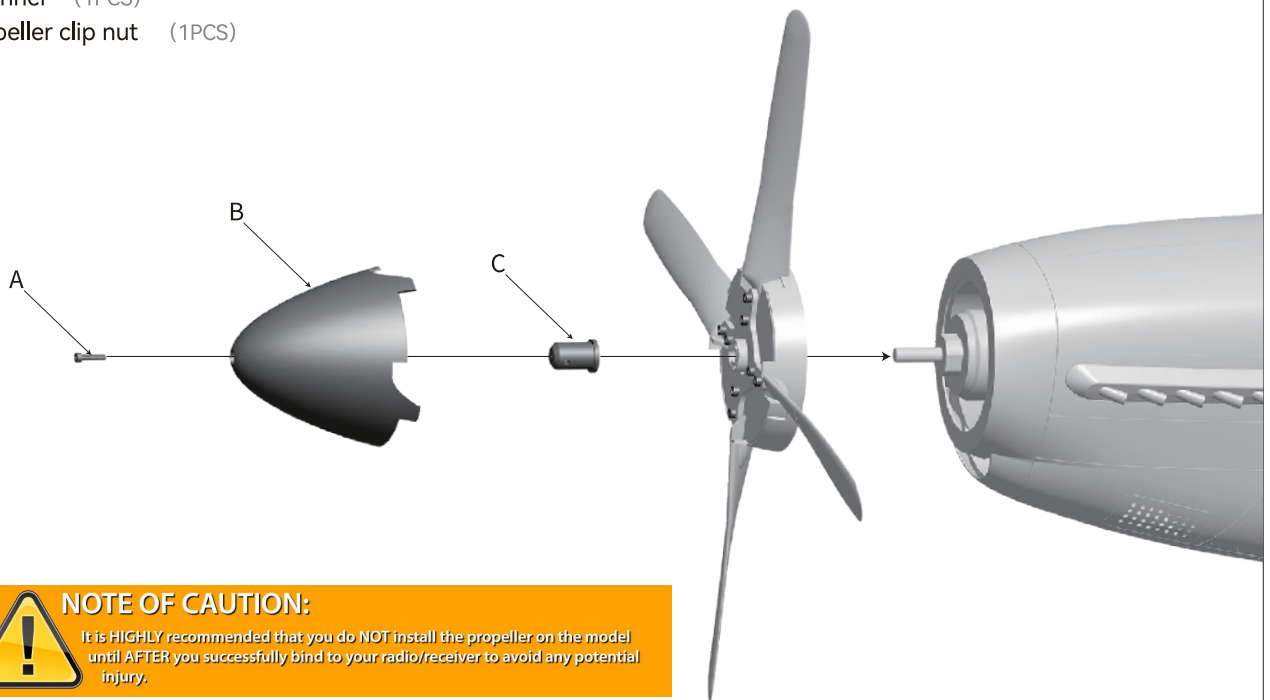

NOTE OF CAUTION:

It is HIGHLY recommended that you do NOT install the propeller on the model until AFTER you successfully bind to your radio/receiver to avoid any potential injury.

Install the Horizontal tail and Vertical tail

As the photo show:

1. Push the horizontal tail into the vertical tail slot;
2. Turn over the tail wing and fix it with screws

Screw (KM 3*7mm 1PCS)

step 1

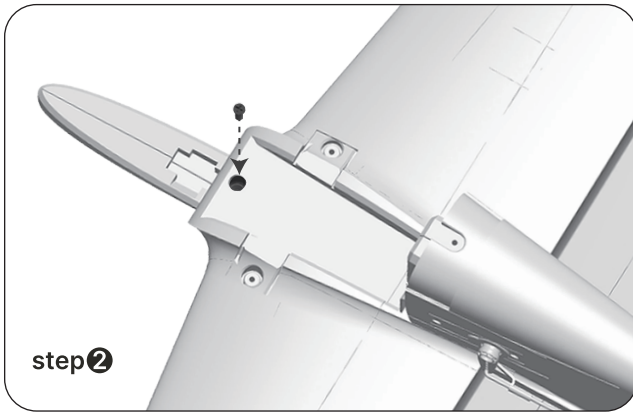
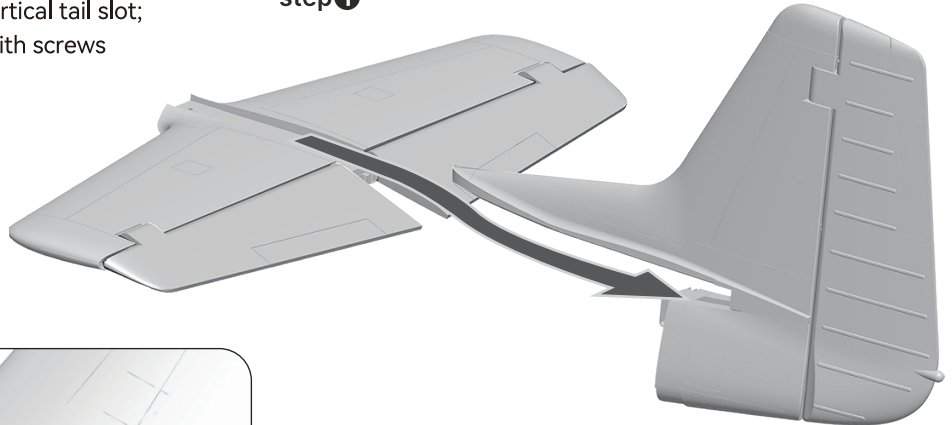

3. Thread the rudder servo cable from the rear fuselage into the equipment compartment, and then connect it to the RUD port of control box.
4. Align the bottom slot of the vertical tail with the slot at the rear fuselage, and then push the vertical tail into the rear fuselage.
5. Turn over the fuselage and fix it with screws.

Screw (KM 3*7mm 3PCS)

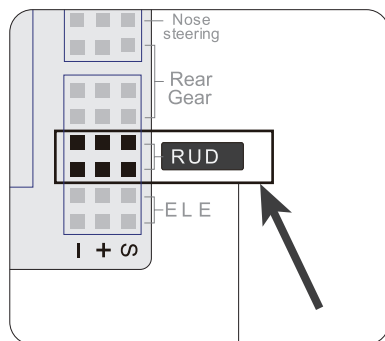

step 1

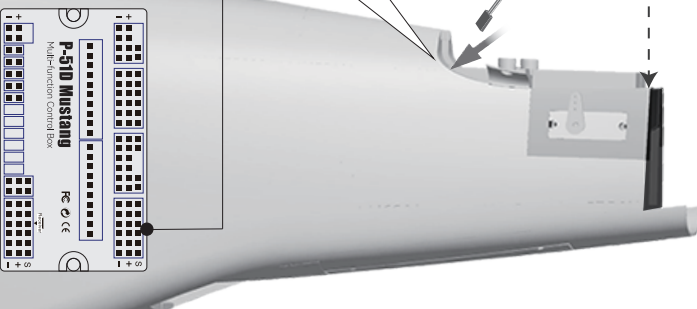
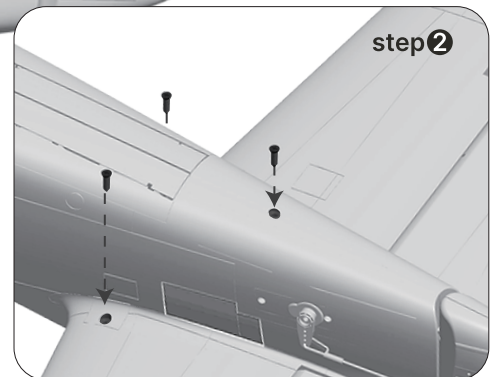

Install Main Wing

As the photo show: Press the fuselage screw-less quick install switch to unlock it ①;

- ① Two different status diagrams of the main wing screw-less quick install switch: (The working mode is to press the button to the bottom and release it. The button pops up to the highest position, which is the unlocked status. Once the button is pressed to the bottom again and released, but the button does not pop up, which is the locked status)

Unlock status

As shown in the following photo:
Press the main wing screw-less quick install switch to the bottom and release it. The button pops up to the highest position, indicating that the main wing has been unlocked and can be easily removed and installed.

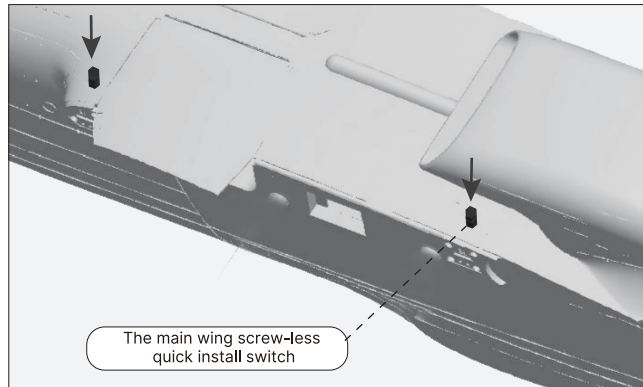

Lock status

As shown in the following photo:
After installed the main wing, press again the main wing screw-less quick install switch to the bottom and release it. If the button does not pop up, it is the locked status. At this point, pull the main wing outward and can not remove it.

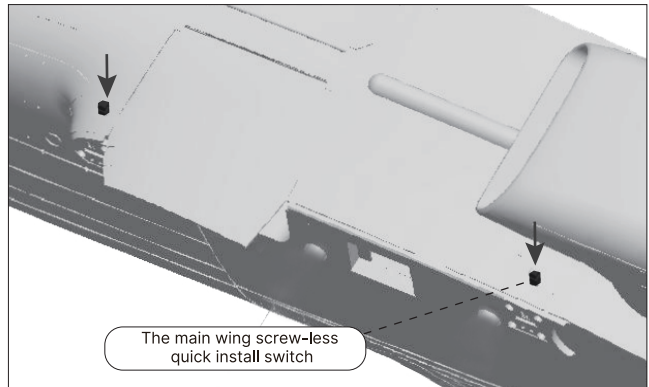

Install Main Wing

As the photo show:

1. Use glue to fix the 【 Conical plastic part 】 on two carbon tubes respectively;

Carbon tube (Ø10x400mm 2PCS)

Conical plastic parts (Ø10mm 4PCS)

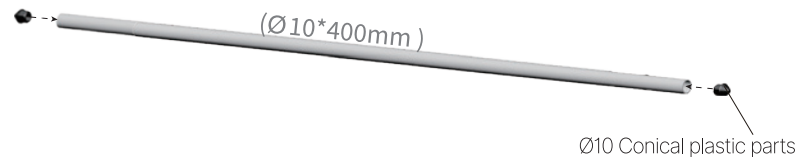

2. Insert carbon fiber tube A and carbon fiber tube B into the fuselage respectively

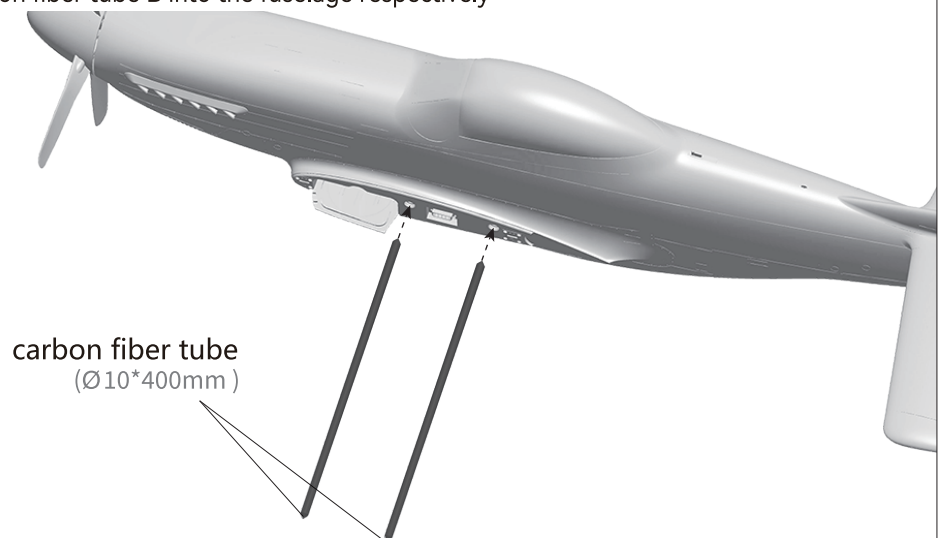

Install Main Wing

3. Install the left and right main wing on the fuselage.

The latch toggle lever of "quick" portable install structure is in unlock status.

When installing the main wing, there is a possibility of collision between the main wing and the cabin door. Use your fingers to gently lift the cabin door upwards to smoothly install the main wing.

4. Press 4 pcs fuselage screw-less quick install switch, put it in the locked status.

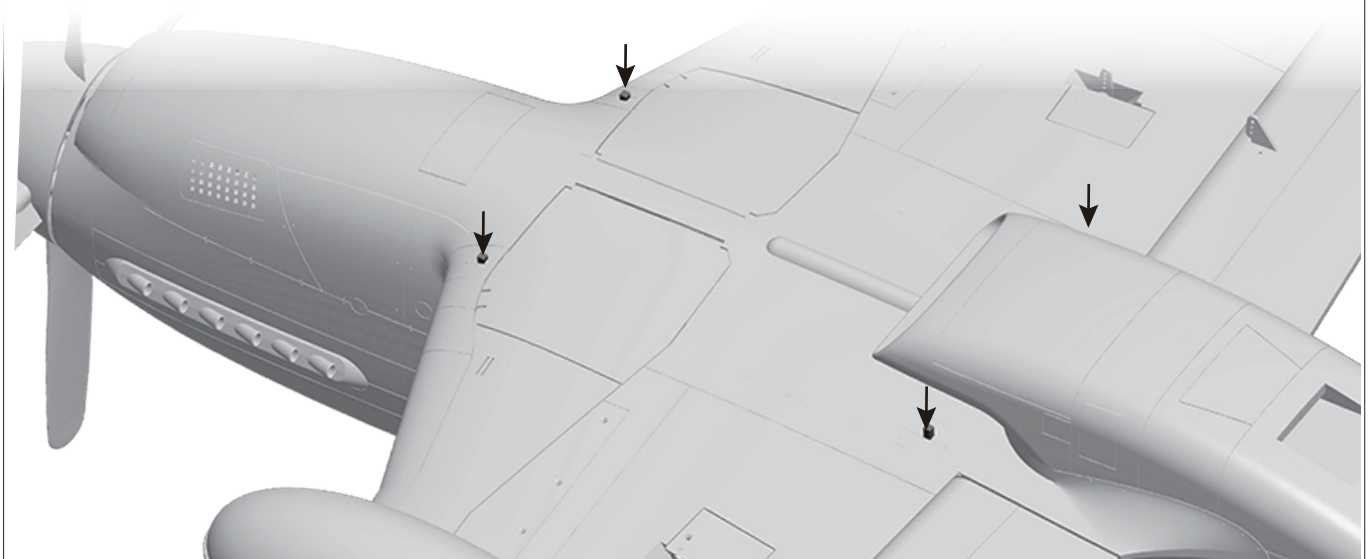

Install other accessories

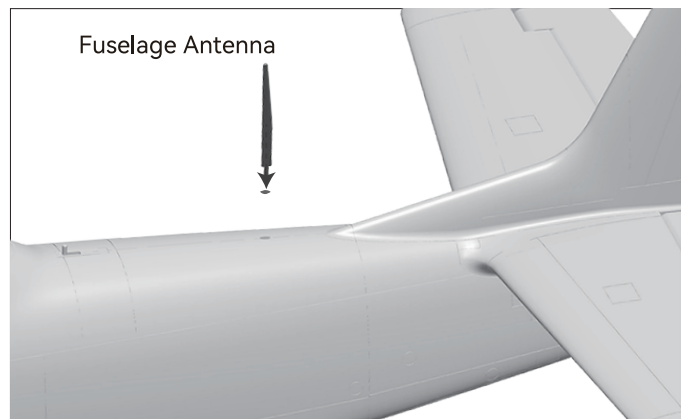
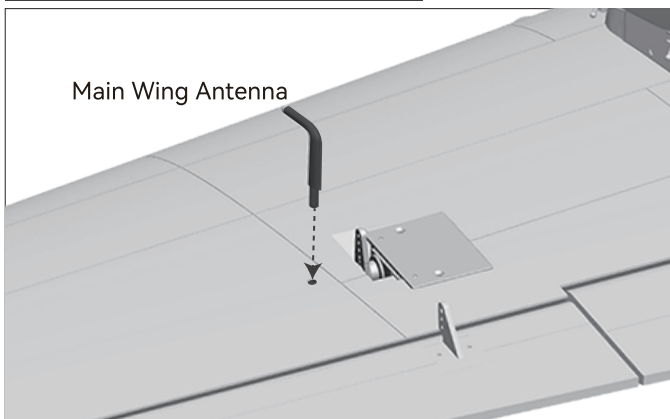

Install the drop tanks

1. Apply the glue evenly to the bonding surface of the drop tank and pylons.
2. Stick the drop tank pylons onto the drop tank.



3. Install the drop tank on the main wing.



Quick Drop Actuator Use instruction

(Quick drop actuator is an optional accessory which can be purchased separately)

1. Connect the quick drop actuator cable to the extension cable, ensuring the extension cable's clip is fully hooked onto the cable plug;
2. Mount the quick drop actuator on the main wing pylon;

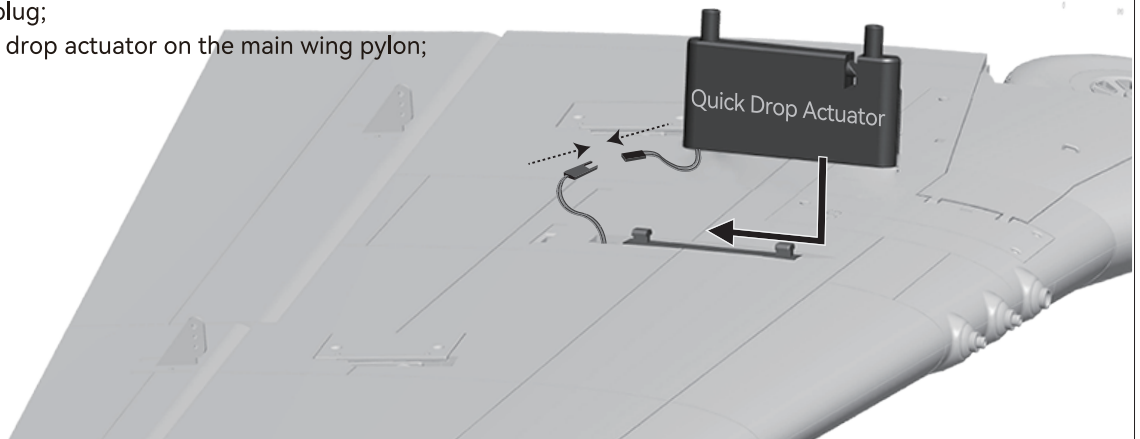

3. Install the drop tank to the quick drop actuator, ensuring the latch locks the tank in place;

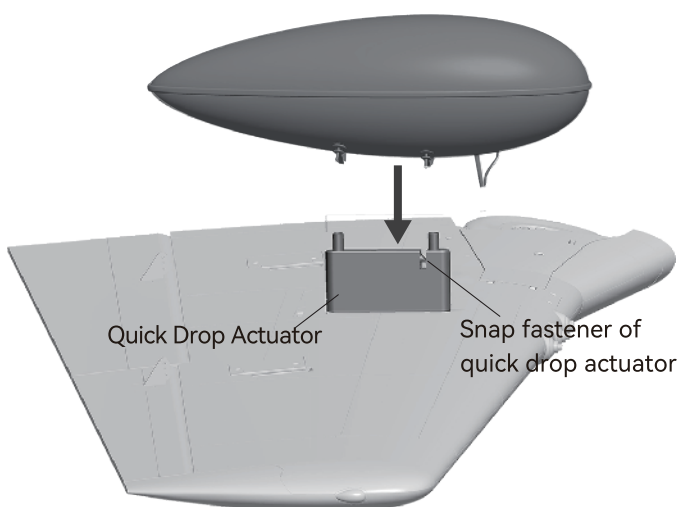

4. As shown in the figure, connect the 【Drop Bombs】 cables to the control box and receiver respectively.

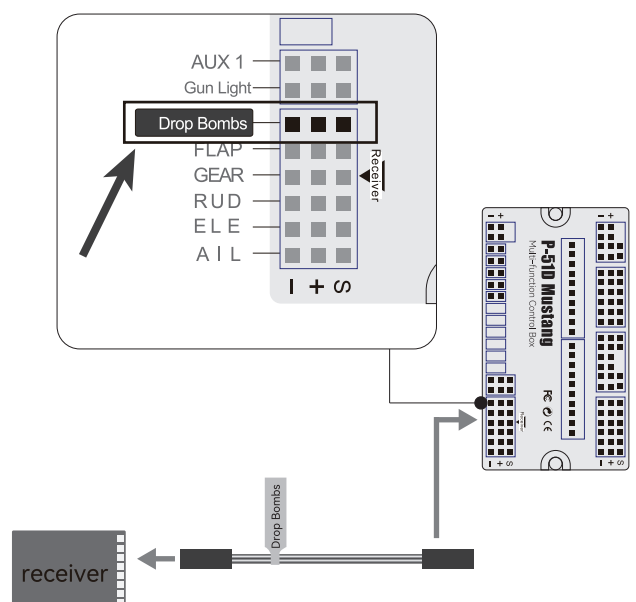

Usage of FPV cabin wood piece

FPV cabin wood piece are optional replacement parts. After removing the original cabin cover and installing this wood piece, it can provide a stable and flat installation platform for your FPV (first person main view) camera equipment to obtain a more realistic flying perspective.

- 1 Tear off the two fixed tapes at the bottom of the cabin;

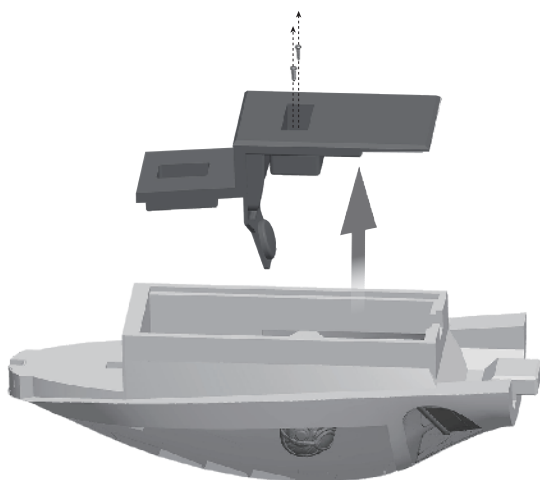
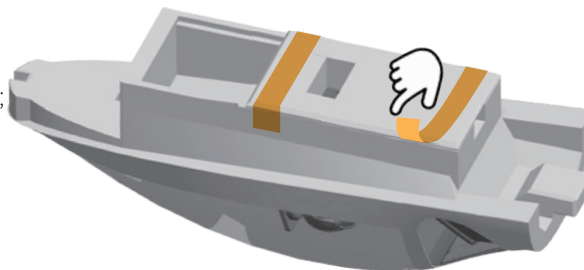

- 2 Remove the two pilot fixing screws at the bottom of the cockpit
- 3 Remove the cockpit base and the pilot

- 4 Install the FPV equipment above the FPV wood piece.

- 5 Apply the glue evenly on the bonding surface of the cabin, and bond the FPV fixing wood piece to the cabin.

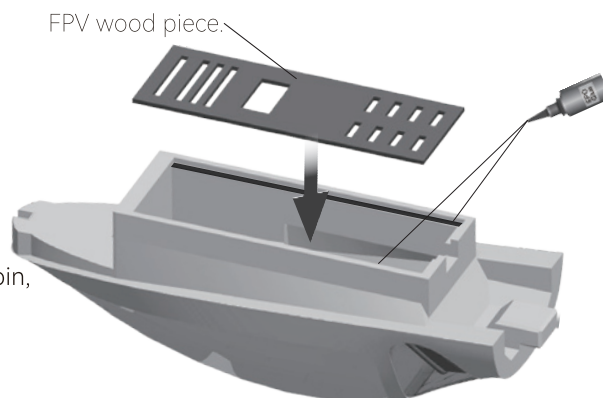

FPV Flight Notes

During FPV flight, the pilot operates through the camera's field of view, which is narrow and prone to losing perception of the overall attitude of the aircraft and the surrounding environment. An assistant must be equipped as an observer, who must always track the aircraft with the naked eye and promptly inform the pilots in case of danger.

Before each flight, a strict inspection must be carried out in an open area away from crowds, buildings, trees, and high-voltage lines. Stay away from high-voltage power towers, large metal structures, and areas with dense Wi Fi signals, which can seriously interfere with your remote control and image transmission signals.

Ensure independent and sufficient power supply for FPV equipment (image transmission, cameras), aircraft receiver, and flight control. Image transmission consumes a lot of power, and unstable voltage can cause signal interruption.

Pushrod Instructions

Elevator pushrod length

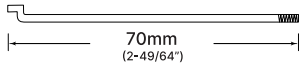

Pushrod diameter \varnothing 1.5mm

Elevator pushrod mounting hole



Rudder pushrod length

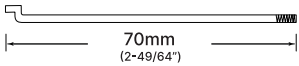

Pushrod diameter \varnothing 1.5mm

Rudder pushrod mounting hole



Aileron pushrod length

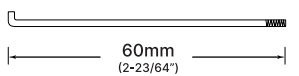

Pushrod diameter \varnothing 1.5mm

Aileron pushrod mounting hole



Flap pushrod length

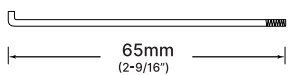

Pushrod diameter \varnothing 1.5mm

Flap pushrod mounting hole

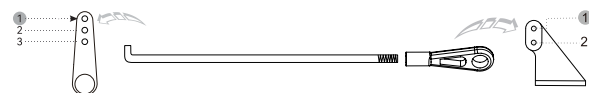

Rear gear steering pushrod length

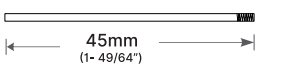

Pushrod diameter \varnothing 1.5mm

Rear gear steering pushrod mounting hole



Nose Cabin door pushrod length

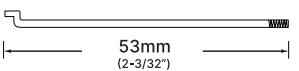

Pushrod diameter \varnothing 1.2mm

Nose Cabin door pushrod mounting hole



Nose follow Cabin door pushrod length

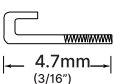

Pushrod diameter \varnothing 1.2mm

Nose follow Cabin door pushrod mounting hole

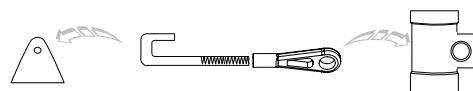

Rear Cabin door pushrod length

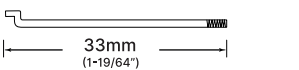

Pushrod diameter \varnothing 1.2mm

Rear follow Cabin door pushrod mounting hole



Nose Gear servo pushrod length

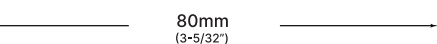
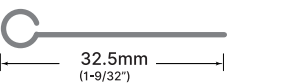

Nose Gear servo pushrod mounting hole

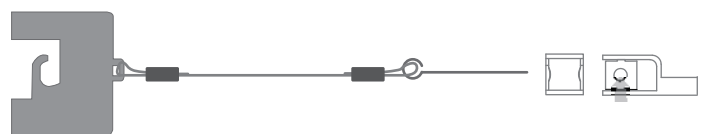

Please refer to the diagram, connect the servo cables to the control board, and connect to the receiver correctly.

- ⚠ Note:** 1. Ensure that each connecting cable is connected in the correct positive and negative directions;
 2. Ensure that the connecting cable is fully inserted into the row pin without loose;

Control board diagram

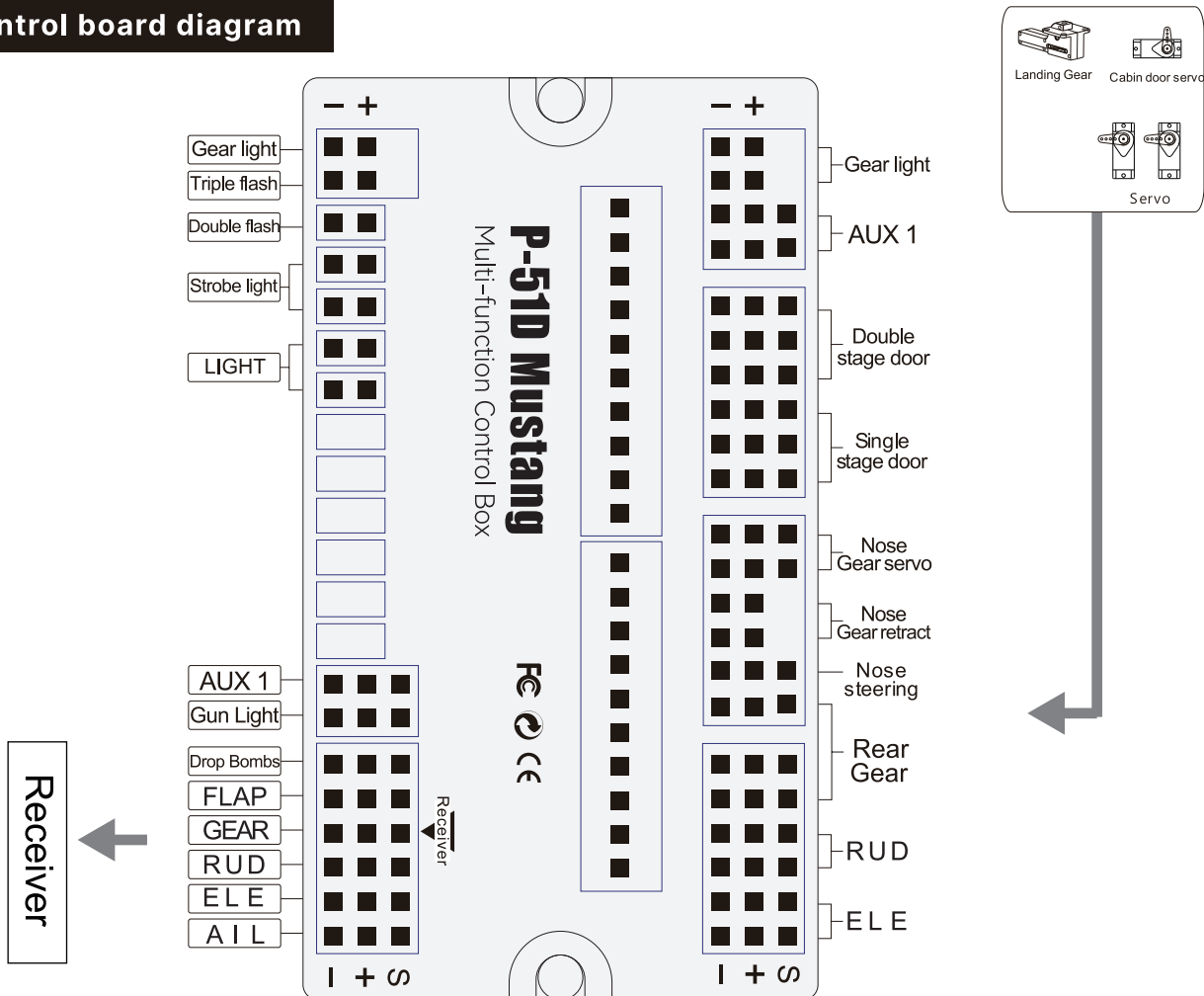

Control board diagram of Main wing

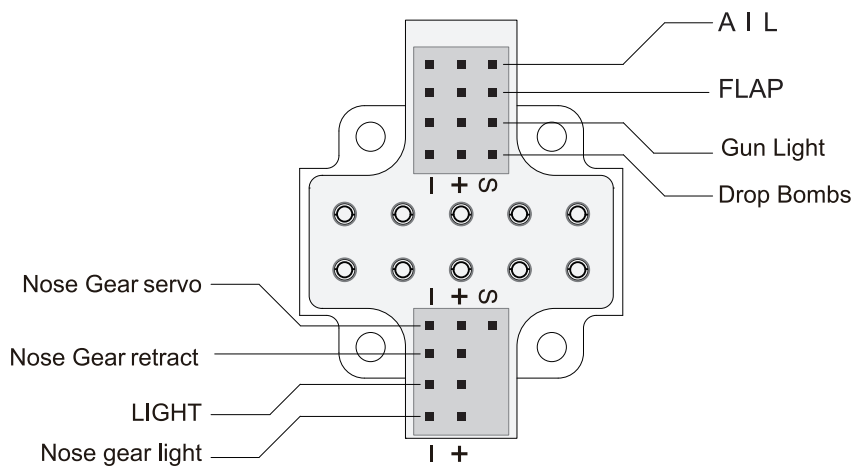

Battery installation instructions

1. Tie the battery to the battery fixing wooden piece with Velcro;
2. Align the battery fixing chip with the middle of the battery chip groove and push it into the machine head.

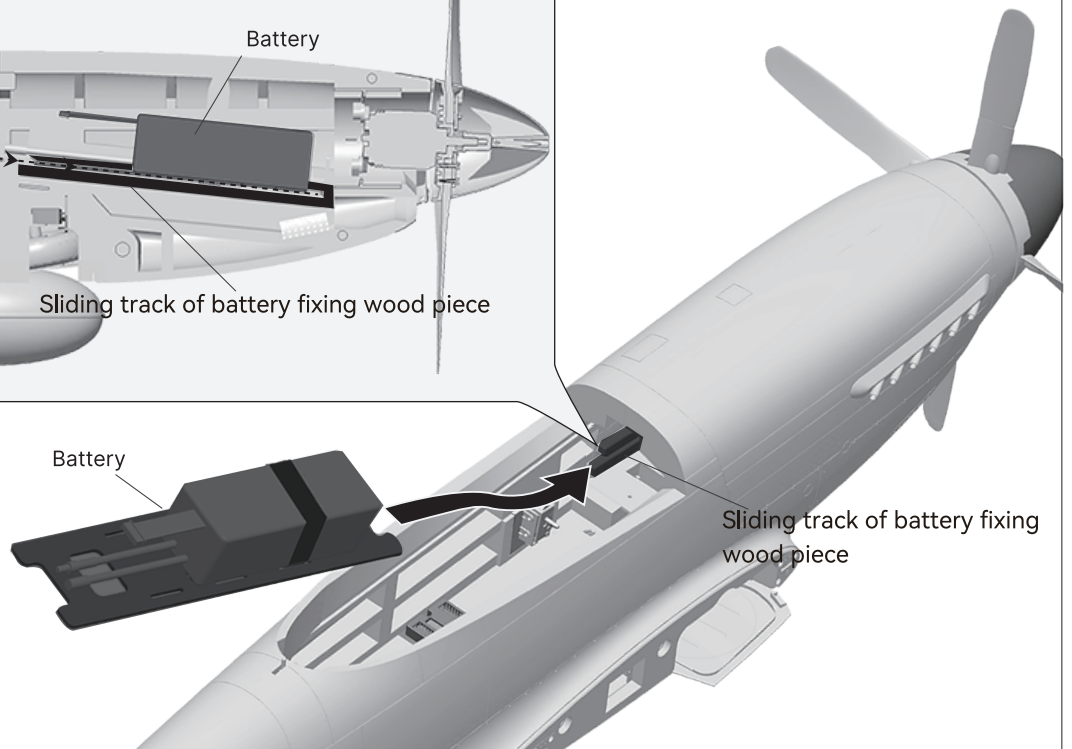
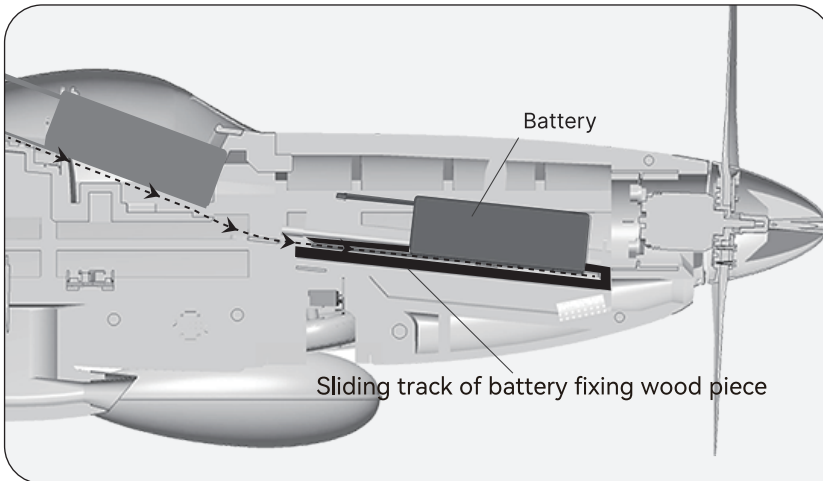
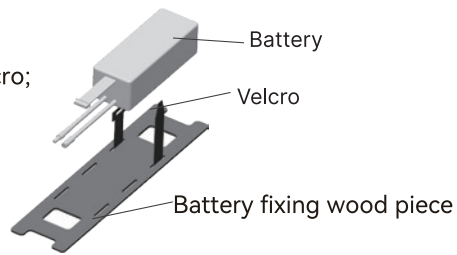

3. After pushing the battery fixed wooden chip to its position, the limiter just needs to clamp the wooden chip
4. If need to remove the battery, simply press the lower limit switch to unlock and remove it.

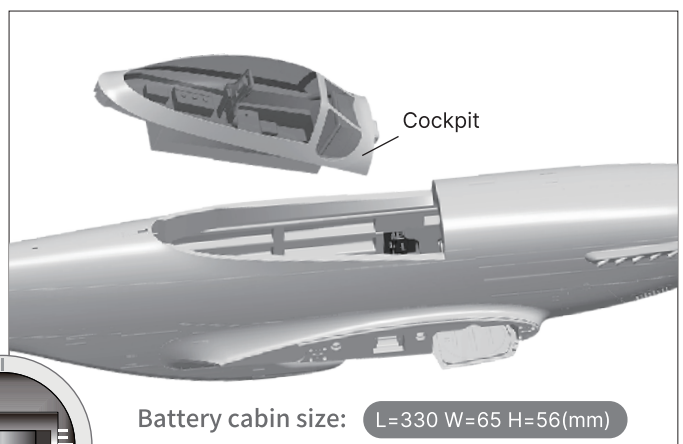
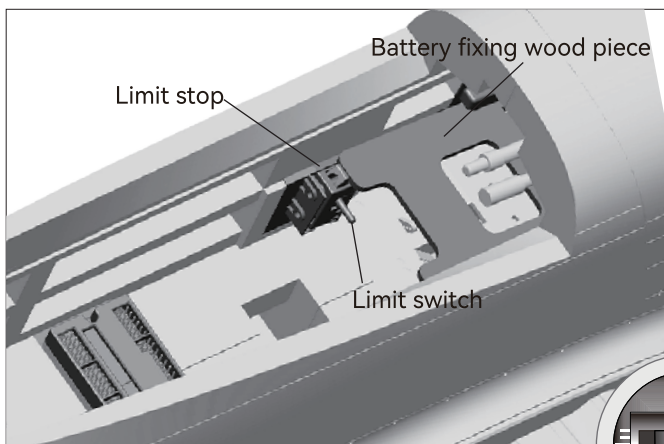

Before connecting the battery and receiver, please switch on the transmitter power and make sure the throttle stick is in the lowest position. Bind your receiver to your transmitter according to your transmitter's instruction manual.

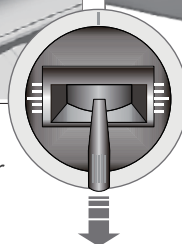

We recommend the following LiPo battery:
6S 22.2V 5000mAh~6S 22.2V 6000mAh (1pcs)
 Discharge rate of C ≥35C

Center of Gravity

Correct Center of Gravity ("CG") is critical for enabling safe aircraft stability and responsive control. Please refer to the following CG diagram to adjust your aircraft's Center of Gravity.

- Depending on the capacity and weight of your chosen flight batteries, move the battery forward or backward to adjust the Center of Gravity.
- If you cannot obtain the recommended CG by moving the battery to a suitable location, you can also install a counterweight to achieve correct CG. However, with the recommended battery size, a counterweight is not required. We recommend flying without unnecessary counterweight.

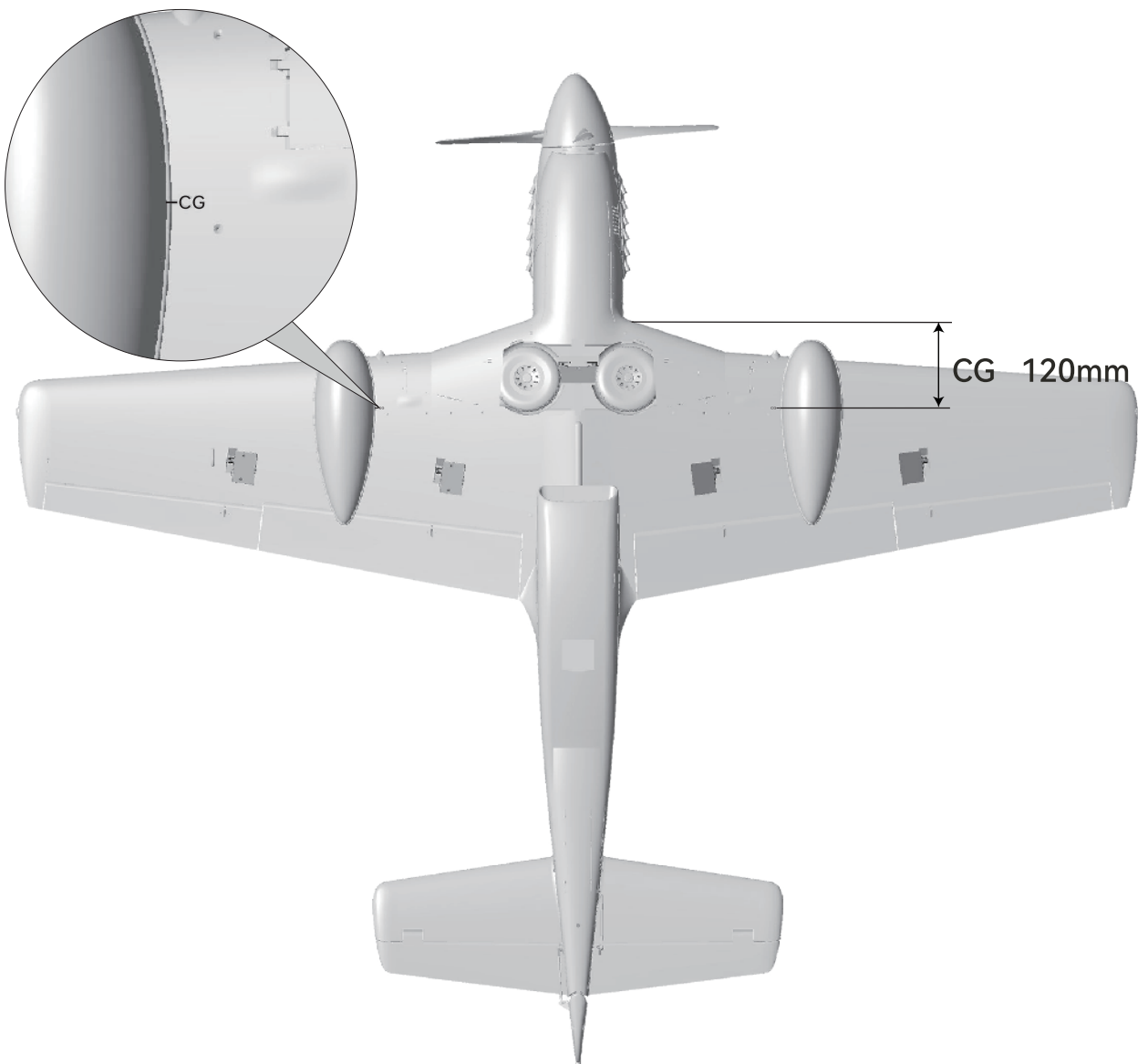

After installed this P-51 model plane, please connect to the receiver and power on, then adjust it.

1. When all channels of radio are fine tuned to zero and the control stick is centered: check whether each control surface on the aircraft is in the center position. If it is found that the control surface is not in the center position, please adjust the control rod to center it;
2. Please refer to the diagram below and use the radio to test each control surface to ensure that its movement direction matches the diagram. If the opposite movement occurs, first check whether the relevant channel in the radio has enabled the reverse function; If the problem persists, please contact us for assistance in resolving it.

Aileron

Stick Left

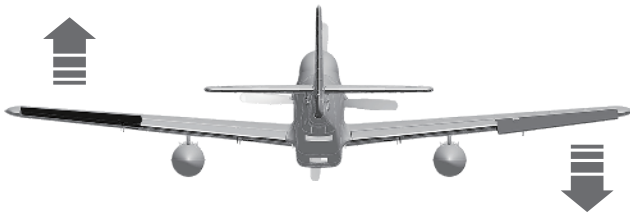

Stick Right



Elevator

Stick down

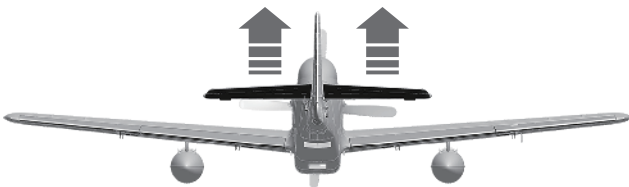

Stick up

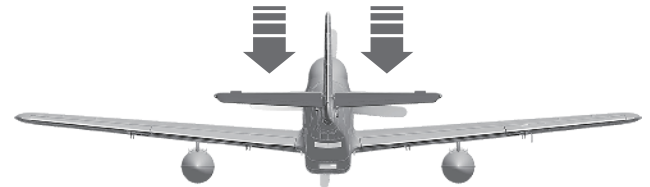

Rudder

Stick Left

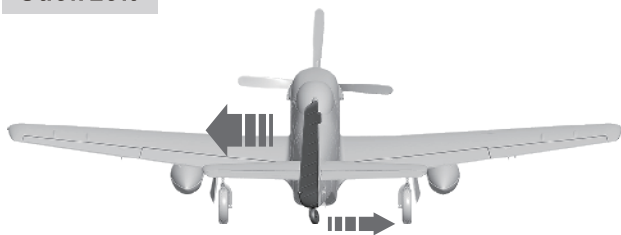

Stick Right

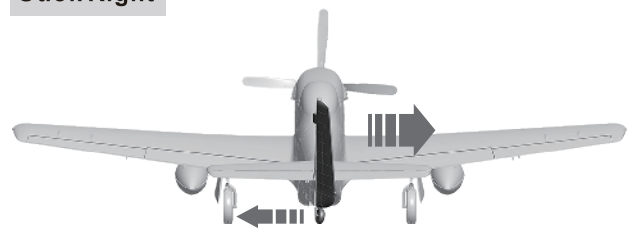

Flaps

Flaps down

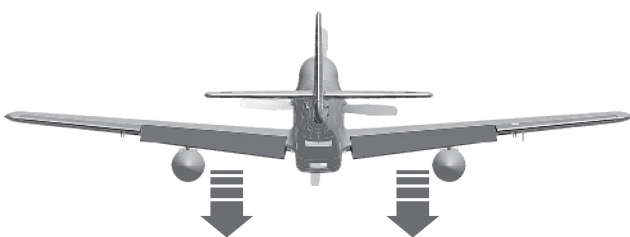

Dual Rates

According to our testing experience, use the following parameters to set Aileron/Elevator Rate. Program your preferred Exponential % in your radio transmitter. We recommend using High Rate for the first flight, and switching to Low Rate if you desire a lower sensitivity. On successive flights, adjust the Rates and Expo to suit your preference.

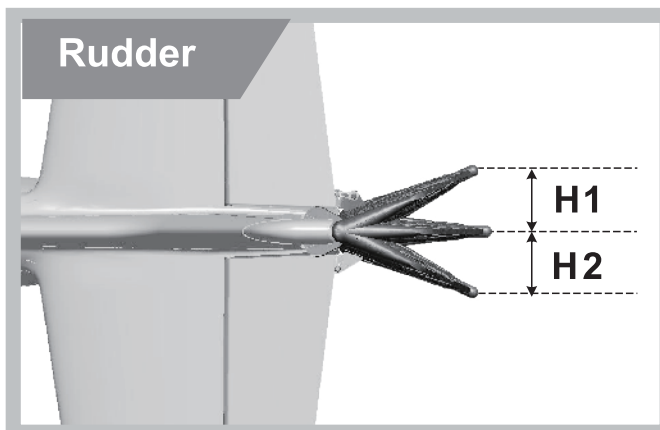
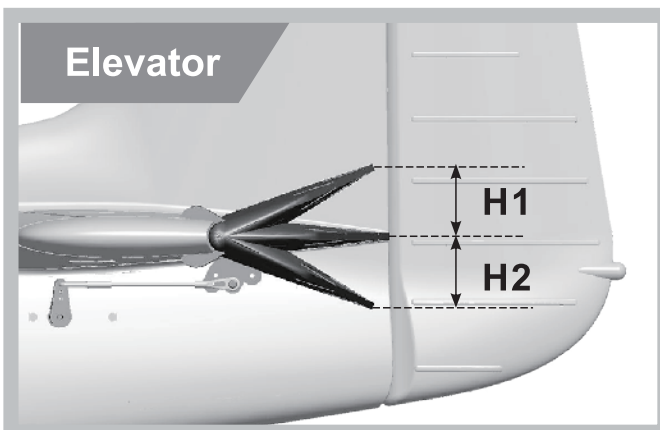
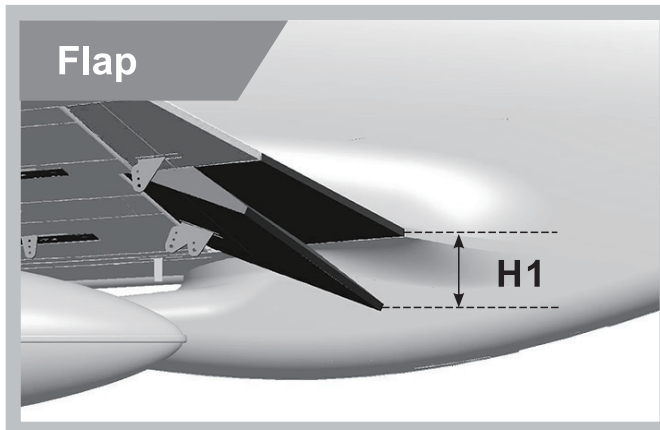
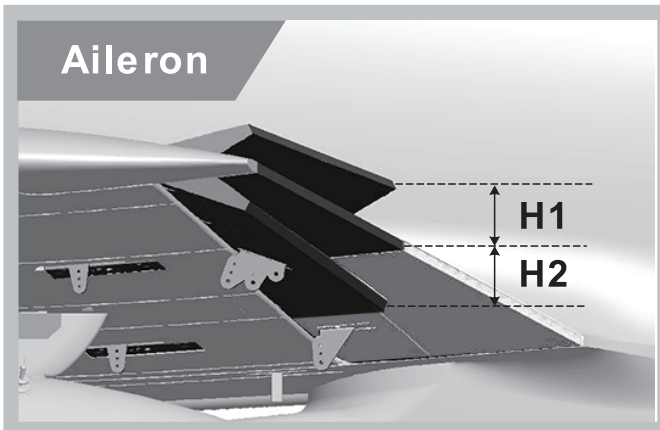

	Aileron (Measured closest to the fuselage)	Elevator (Measured closest to the fuselage)	Rudder (Measured from the bottom)	Flaps Measured closest to the fuselage
Low Rate	H1/H2 28mm/28mm D/R Rate: 80%	H1/H2 14mm/14mm D/R Rate: 100%	H1/H2 43mm/43mm D/R Rate: 80%	H1 21mm
High Rate	H1/H2 35mm/35mm D/R Rate: 100%	H1/H2 14mm/14mm D/R Rate: 100%	H1/H2 51mm/51mm D/R Rate: 100%	H1 39mm

⚠ Flight Attention:

1. Flap-elevator mix parameter

When deploy the flap, the jet will change the flight direction, it will fly down the sky. In order to operate better, we advise you set the "Flap-elevator mix" in radio. In this case, when you deploy the flap, the jet don't change its flight.

With low rate flaps deployed, mix 0.9mm of UP elevator.

With high rate flaps deployed, mix 1.5mm of UP elevator.

At last, according to your operating, you can increase or reduce its rate

2. Flight note:

An elevator down 1mm is required to maintain level flight when full throttle fly as the right photo shown.

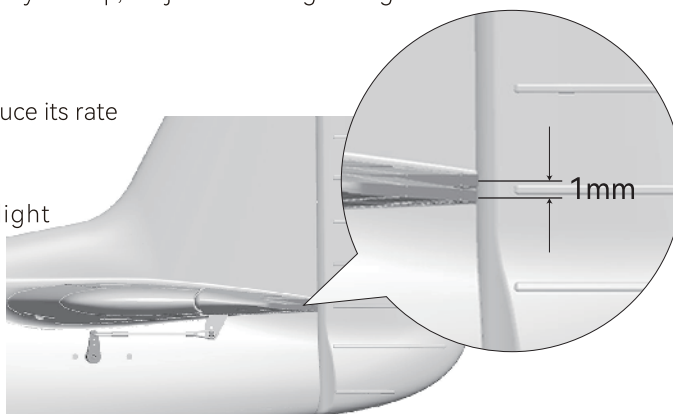

Remote Control EXP Setting Suggestion

1. Aileron EXP curve is shown as below :

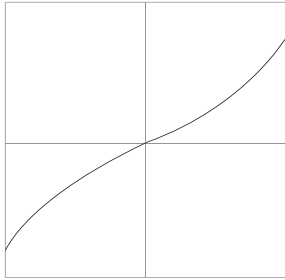

Futaba brand Remote Control : EXP A -30
EXP B -30

Spektrum brand Remote Control : EXPO 30% 30%

2. Elevator EXP curve is shown as below :

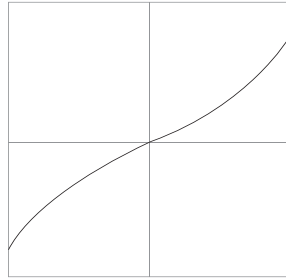

Futaba brand Remote Control : EXP A -30
EXP B -30

Spektrum brand Remote Control : EXPO 30% 30%

3. Rudder EXP curve is shown as below :

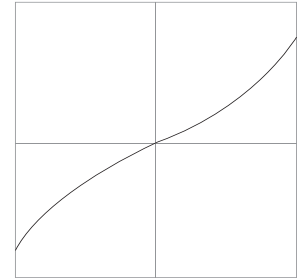

Futaba brand Remote Control : EXP A -30
EXP B -30

Spektrum brand Remote Control : EXPO 30% 30%

Servo Direction

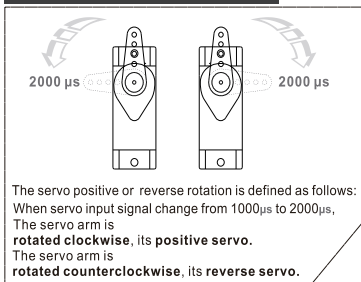

If you need to purchase another brand's servo, please refer to the following list to choose a suitable servo.

Position	Servo regulation	No.	Pos. / Rev.	Cable length
Rear Cabin door	9g plastic servo	1	Positive	700mm
Nose Cabin door (L)	9g plastic servo	2	Reverse	300mm
Nose Cabin door (R)	9g plastic servo	3	Positive	300mm
Nose gear steering servo	9g Digital-Hybrid	4	Positive	500mm
landing gear locking servo (L)	9g Digital-MG	5	Positive	200mm
landing gear locking servo (R)	9g Digital-MG	6	Reverse	200mm
Elevator	23g Digital-MG	7	Positive	700mm
Flap(L)	17g Digital-MG	8	Positive	200mm
Flap(R)	17g Digital-MG	9	Reverse	200mm
Aileron(L)	17g Digital-MG	10	Positive	500mm
Aileron(R)	17g Digital-MG	11	Positive	500mm
Rudder	17g Digital-MG	12	Positive	800mm

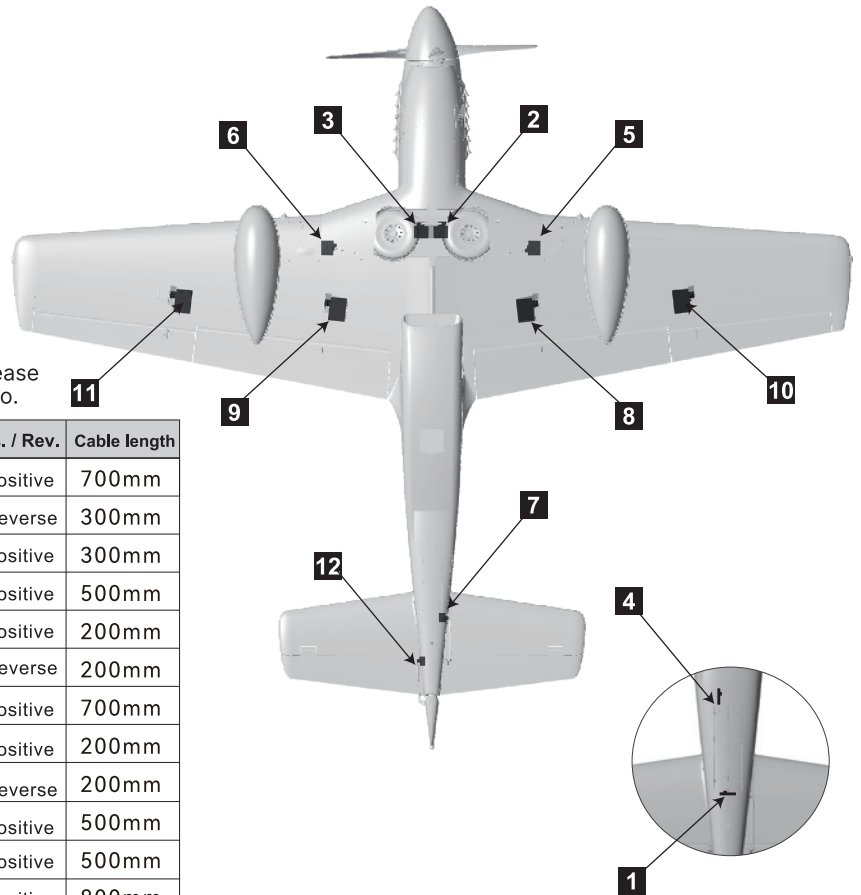

Motor Specification

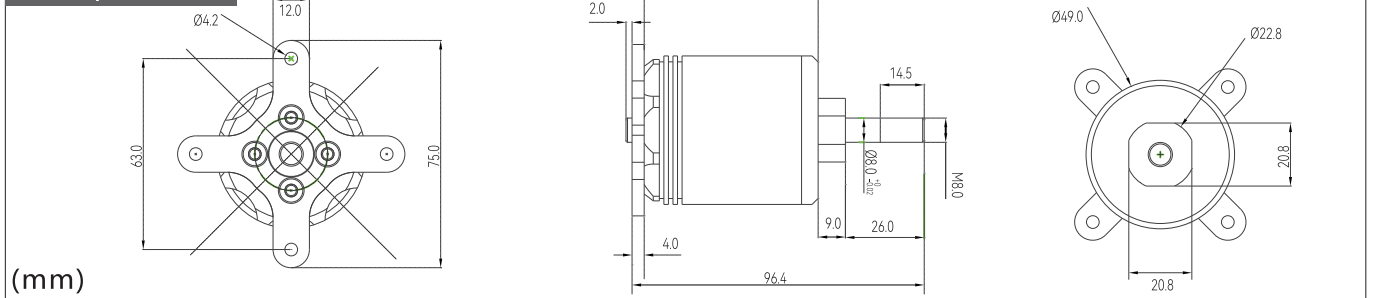

Item No.	KV Value	Volute (V)	Current (A)	Pull (g)	Motor Resistance	Weight (g)	No Load Current	Propeller	ESC
MO150553	5055-390KV	22.2	73	6100	0.02 Ω	410	2.3A/10V	16x12 4-Blade	≥80A

