

**MODEL**  
**Freewing**

[www.freewing-model.com](http://www.freewing-model.com)

# **FREEWING** **MiG-29 Fulcrum**

## **User Manual**

**Wingspan: 1257mm**

**Length: 1878mm**

**Empty Weight: 4300G[w/o Battery]**



[www.freewing-model.com](http://www.freewing-model.com)

EN	1~9
中	10~18

1	Introduction
2	Product basic information
2	Package list
	PNP Assembly instructions
3	Install Fuselage
4	Install Horizontal Stabilizer
4	Install Vertical Stabilizer
4	Install Main Wing
5	Install other accessories
5	Install battery
6	Pushrod instructions
6	Center of Gravity
	PNP Parameter setting
7	Control direction test
8	Dual rates
8	The Elevator Center Position
	Pre-installed component overview
9	Servo direction
9	Motor specification

Freewing first established the Twin 80mm class of EDF jets with its popular F-14 Tomcat then A-10 Warthog, and now we are proud to announce the Freewing MiG-29 Fulcrum! Represented in 1/9 scale, this large aircraft is 1878mm (74") long with a 1257mm (50") wingspan, powered by dual inrunner 80mm EDF power systems.

Computer designed and hand crafted, each Freewing MiG-29 represents the highest level of engineering for a modern Plug-And-Play EDF jet in 2020. Constructed from EPO foam, carbon, wood, aluminum, and other materials, the Freewing MiG-29 is optimized for high performance and superb scale handling. Its wide 50" wingspan and lifting body design provides gentle flight characteristics. Large flaps and suspension landing gear give pilots confident operation on grass airfields. An accurate overall outline, scale ordnance on removable pylons, and articulating landing gear doors enhance the model's scale fidelity. Twist-and-Turn main retracts provide improved aerodynamics, and screw-together assembly gets modelers into the air quickly!

The Freewing MiG-29's uses our popular 80mm Inrunner power system that is proven across thousands of Freewing jets worldwide. Rapid acceleration, enhanced acrobatic envelope, and efficient energy consumption are key features of the Freewing MiG-29 Fulcrum. With high quality flight batteries, the MiG-29 can achieve airspeeds approaching 120mph/193kph in level flight!

**⚠ NOTE:** This is not a toy. Not for children under 14 years. Young people under the age of 14 should only be permitted to operate this model under the instruction and supervision of an adult. Please keep these instructions for further reference after completing model assembly.

### Note:

- 1.This is not a toy! Operater should have a certain experience, beginners should operate under the guidance of professional players.
- 2.Before install, please read through the instructions carefully and operate strictly under instructions.
- 3.Cause of wrong operation, Freewing and its vendors will not be held responsible for any losses.
- 4.Model planes' players must be on the age of 14 years old.
- 5.This plane used the EPO material with surface spray paint, don't use chemical to clean, otherwise it will damage.
- 6.You should be careful to avoid flying in areas such as public places, high-voltage-intensive areas, near the highway, near the airport or any other place where laws and regulation clearly prohibit.
- 7.You cannot fly in bad weather conditions such as thunderstorms, snows....
- 8.Model plane's battery, don't allowed to put in everywhere. Storage must ensure that there is no inflammable and explosive materials in the round of 2M range.
- 9.Damaged or scrap battery should be properly recycled, it can't discard to avoid spontaneous combustion and fire.
- 10.In flying field, the waste after flying should be properly handled, it can't be abandoned or burned.
- 11.In any case, you must ensure that the throttle is in the low position and transmitter switch on, then it can connect the lipo-battery in aircraft.
- 12.Do not try to take planes by hand when flying or slow landing process. You must wait for landing stop, then carry it.



**Standard Version**

Wingload: 125 g/dm<sup>2</sup>  
 Wing Area: 34.2 dm<sup>2</sup>  
 Motor: 3658-1920KV I/R Motor ×2  
 Servo: 9g MG digital servo ×2  
 17g MG digital servo ×9  
 ESC: Dual100A with 8A UBEC ×1  
 Ducted fan: 80mm 9-blade fan ×2  
 Weight: 4300g (w/o Battery)

**Other features**

Material: EPO  
 Aileron: Yes Flap: Yes  
 Elevator: Yes Rudder: Yes  
 Landing gear: Electric Landing Gear  
 Cabin door: Nose gear & Rear cabin door  
 Scale LED lights  
 Scale Pilot figure ×1  
 Li-Po Battery: 6S 22.2V 4000-5200mAh ×2

**⚠ Note:** The parameters in here are derived from test result using our accessories. If use other accessories, the test result will be different. Any problem since of using other accessories, we are not able to provide technical support.

**Package List**

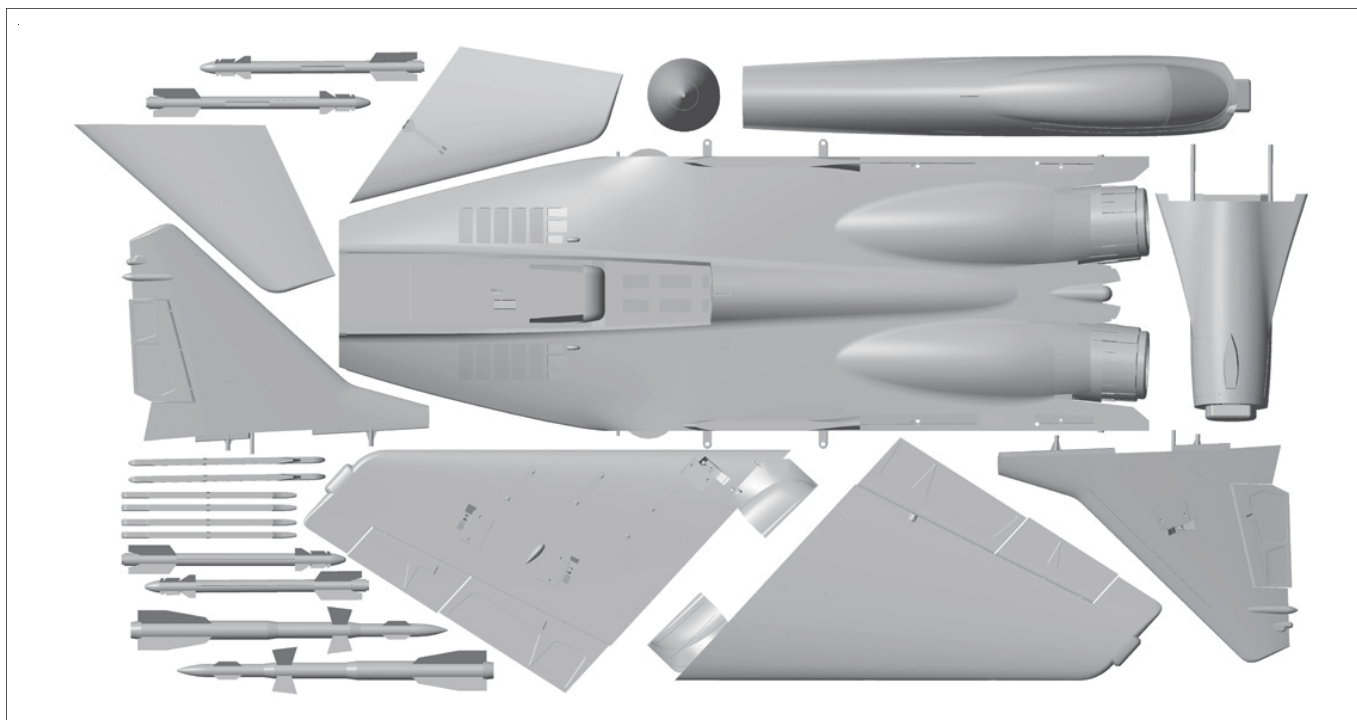

Different equipment include different spareparts. Please refer to the following contents to check your sparepart list.

No.	Name	PNP	ARF Plus	No.	Name	PNP	ARF Plus
1	Fuselage	Pre-installed all electronic parts	Pre-installed servo	6	Cockpit and Nose cone	✓	✓
2	Main wing	Pre-installed all electronic parts	Pre-installed servo	7	Manual	✓	✓
3	Horizontal tail	Pre-installed all electronic parts	Pre-installed servo	8	Pushrod	✓	✓
4	Vertical tail	Pre-installed all electronic parts	Pre-installed servo	9	Non-slipmat	✓	✓
5	Missiles	✓	✓	10	Screw and Carbon tube	✓	✓

## Install Fuselage

1. Apply glue evenly to the exposed carbon fiber tube surface of the front fuselage.
2. Apply glue evenly on the dark area of rear fuselage.

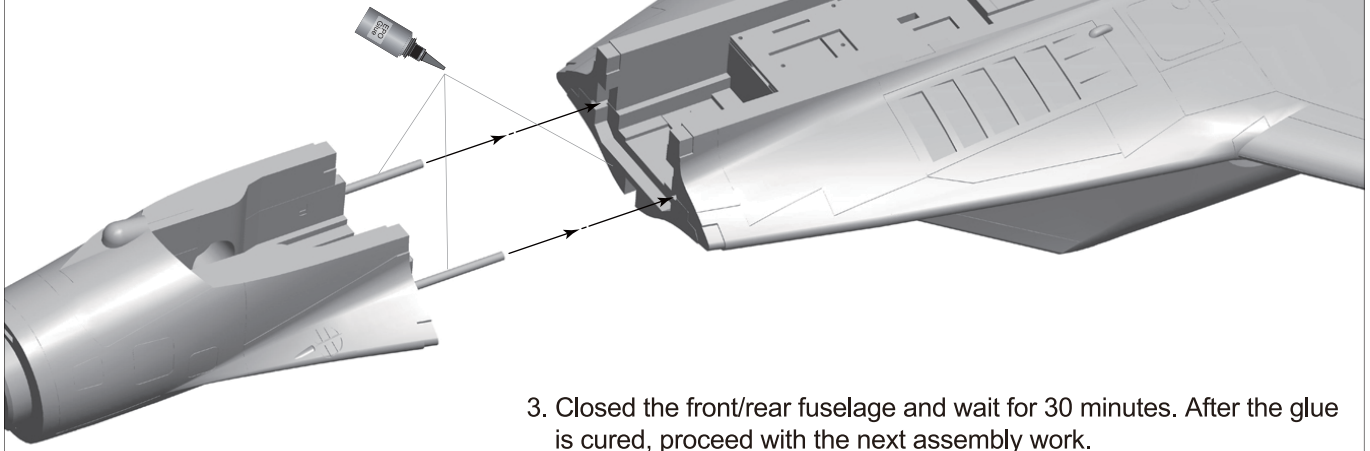

4. Take out the plastic protective cover in the accessory bag.
5. Use glue to glue these plastic parts to the position shown in the figure.

**Note:** The inside of the plastic protective cover is marked with left (L) and right (R) characters to distinguish its use position, please install it correctly according to the picture.

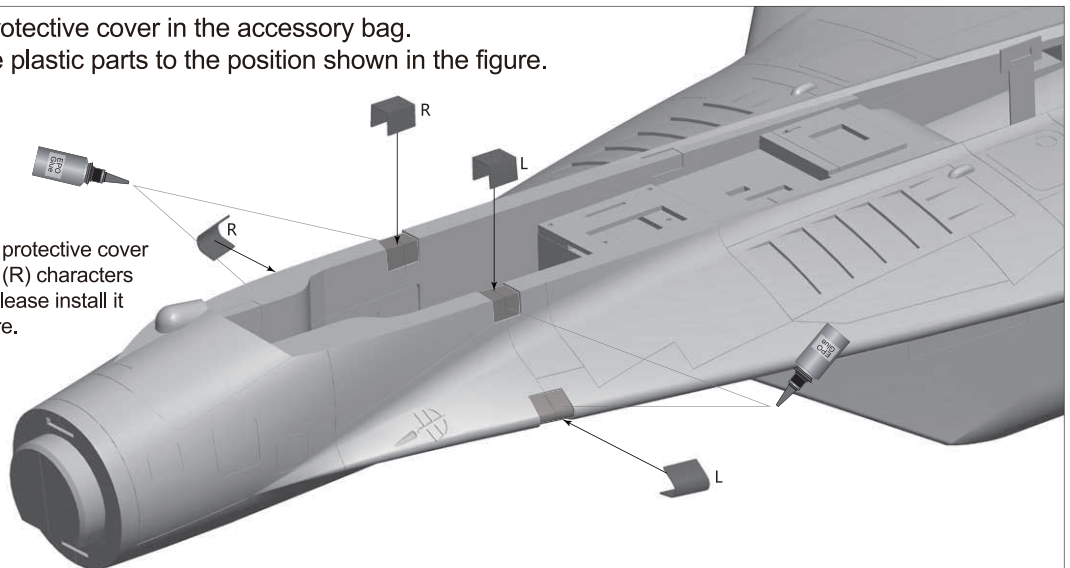

6. Take out the battery fixing plate and fix it in the battery compartment with screws.

Screw (PA3×10mm 4pcs)

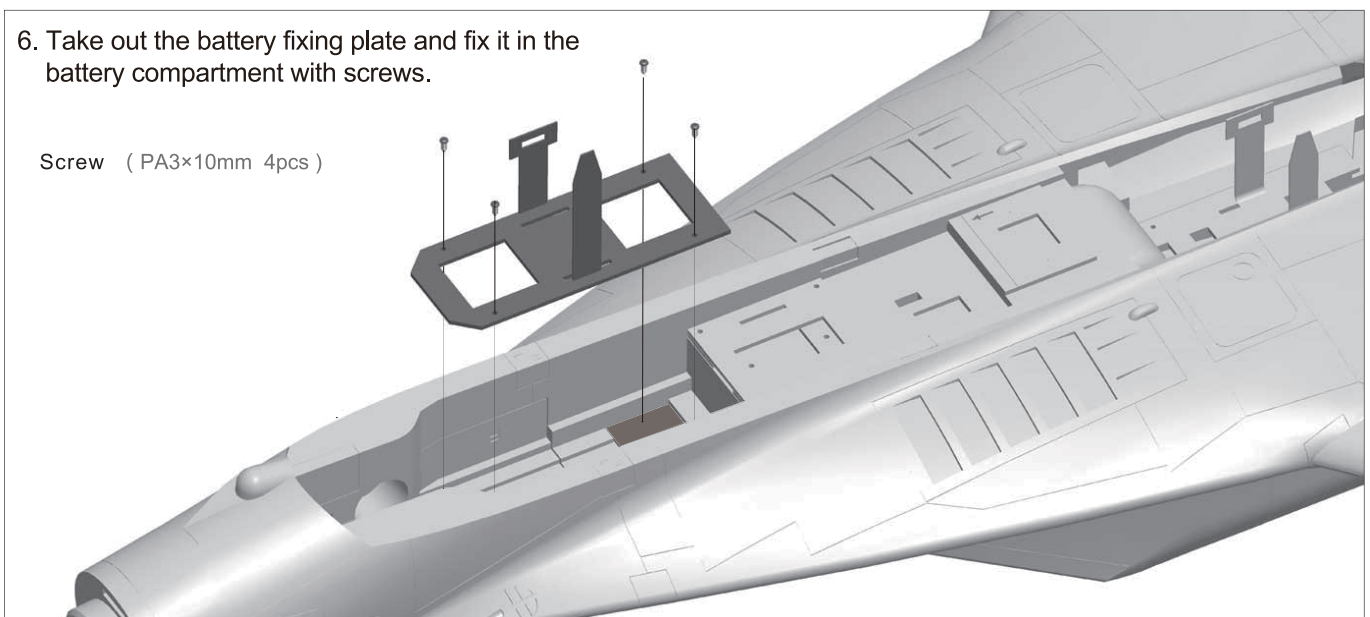

**Install Horizontal Stabilizer**

1. Turn over the fuselage, and let the belly is up. Then begin to install the full-elevator horizontal tail.
2. Insert the full-elevator rotating shaft into the fixing hole, and fix it with screws.
3. Put the horizontal tail which installed the elevator horn into the rotating shaft and fix it with the fixing ring.
4. Follow the above steps to install the full elevator horizontal tail on the other side.

Screw ( PT3×8mm 4pcs )



When fixing the horizontal tail rotating shaft, make sure the screw is aligned with the anti-loosening groove on the rotating shaft.

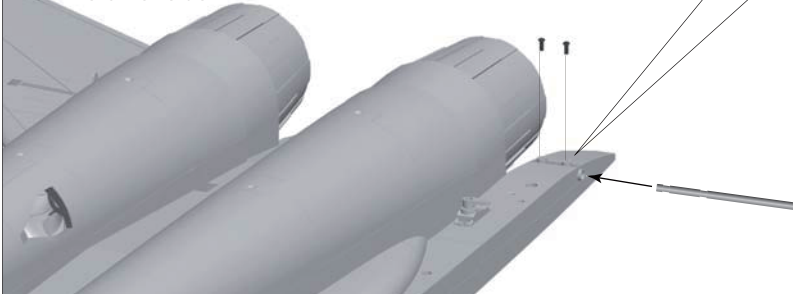

Fixing ring

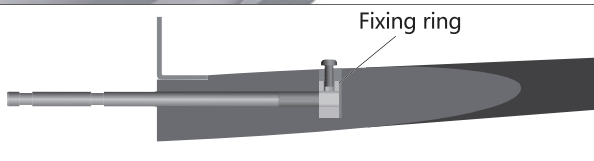

1. First lock the screw into the fixing ring, and lock it into half of the depth.
2. Place the retaining ring in the horizontal tail groove.
3. Put the horizontal tail into the rotating shaft, adjust the position of the fixing ring, and finally tighten the screw.

Screw ( PM2×4mm 2pcs )

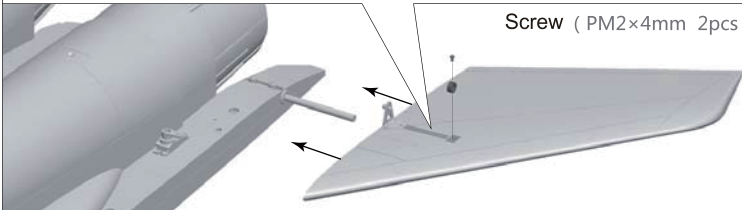

**Install Vertical Stabilizer**

1. Put on the fuselage, and take out the vertical stabilizer.
2. As shown in the photo, connect the vertical tail servo cable and the extension cable, and then insert the vertical tail into the fixed groove of the fuselage. Screw in the screws from below to secure the vertical Stabilizer.
3. Repeat the above steps to install the vertical tail on the other side.

Screw ( PA3×10mm 4pcs )

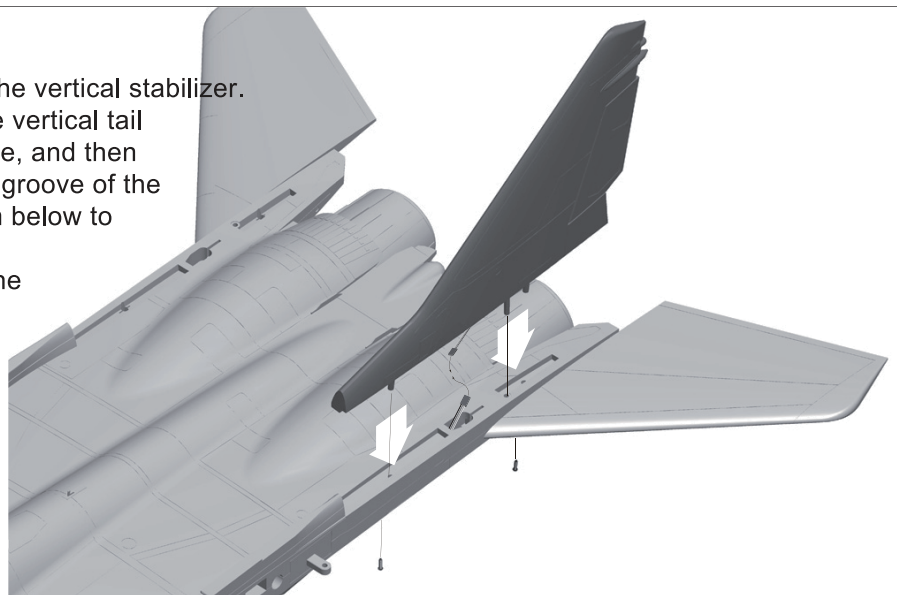

**Install Main wing**

1. Insert the carbon tube into the fuselage and keep the two ends exposed to the same length.

Carbon tube size : Ø14×650mm

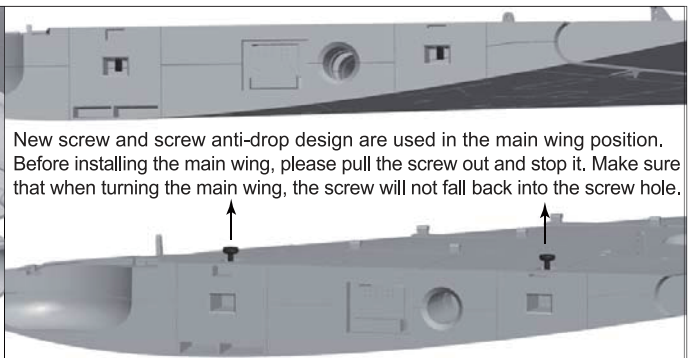
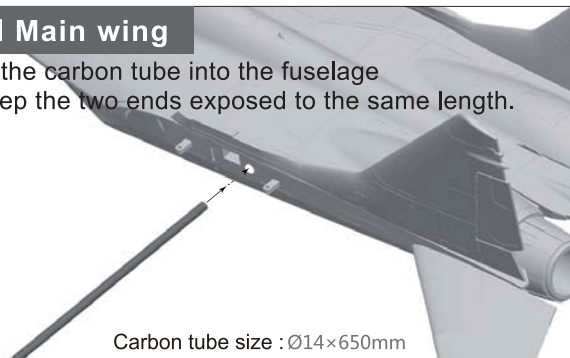

New screw and screw anti-drop design are used in the main wing position. Before installing the main wing, please pull the screw out and stop it. Make sure that when turning the main wing, the screw will not fall back into the screw hole.

**Install Main wing**

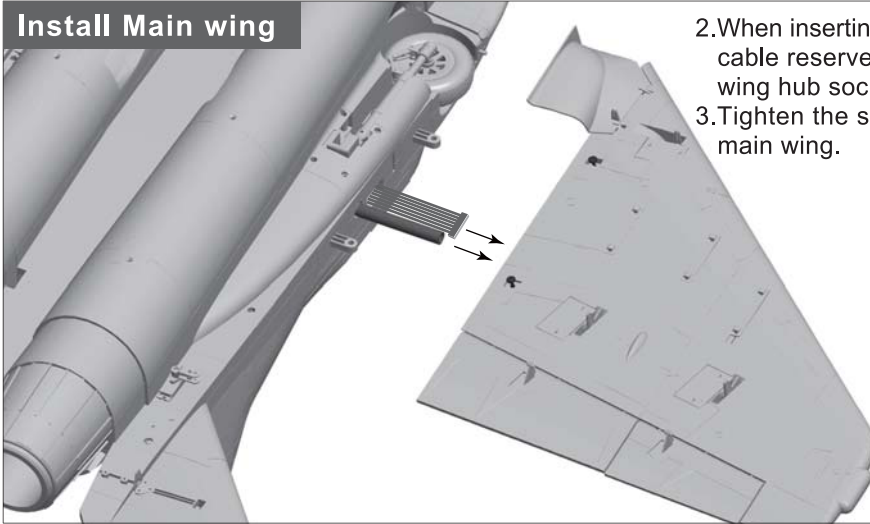

2. When inserting the main wing into the fuselage, insert the cable reserved on the side of the fuselage into the main wing hub socket and then close it.
3. Tighten the screws attached to the main wing to fix the main wing.

Anti-loosening screw : ( M4×16mm 4pcs )

**Install Missiles, Pylons and Antenna**

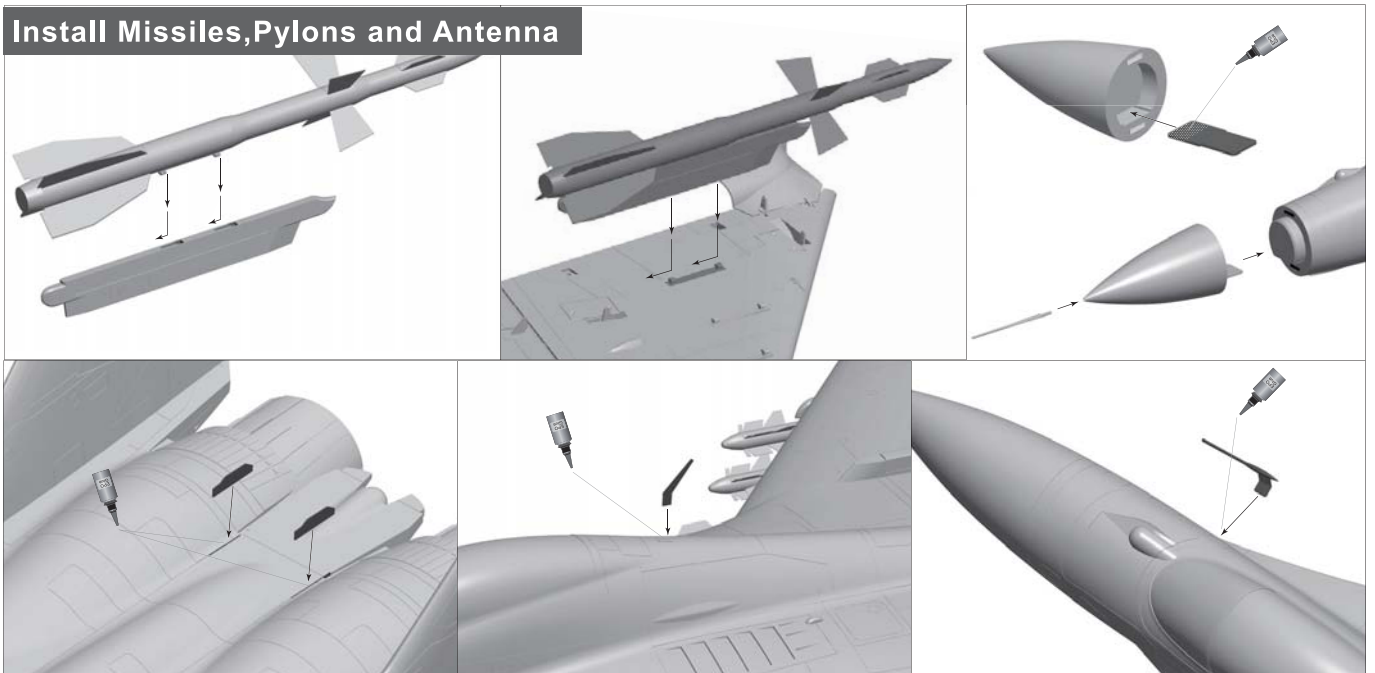

**Install Battery**

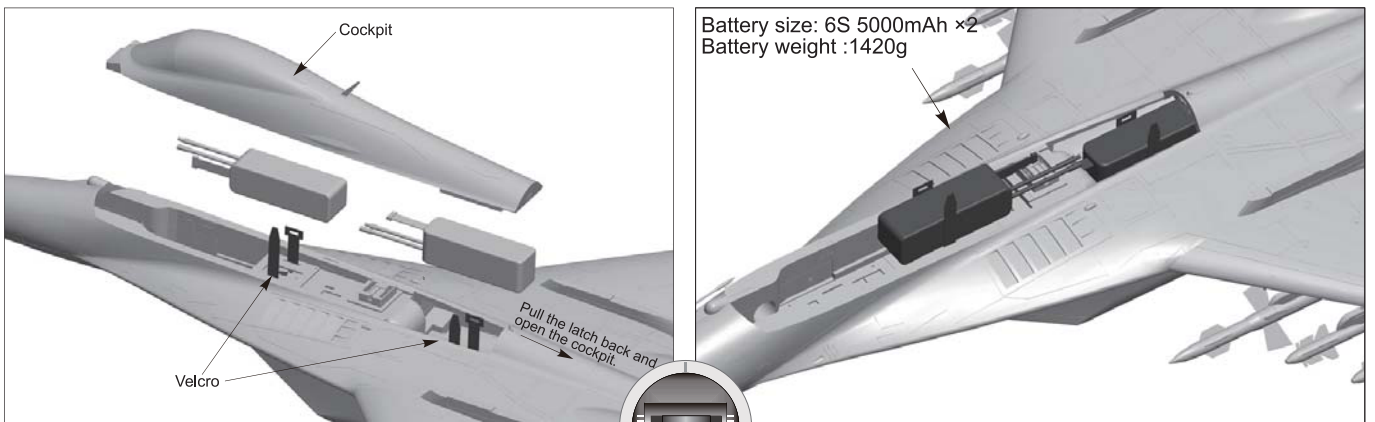

Battery size: 6S 5000mAh ×2  
Battery weight :1420g

Before connecting the battery and receiver, please switch on the transmitter power and make sure the throttle stick is in the lowest position. Bind your receiver to your transmitter according to your transmitter's instruction manual.

We recommend the following LiPo battery:  
**6S 22.2V 4000mAh~6S 22.2V 5200mAh**  
Discharge rate of C ≥ 35C

**Pushrod instructions**

**Nose gear steering pushrod length**

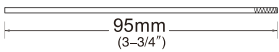

Pushrod diameter  $\varnothing 1.5\text{m}$

**Nose gear steering pushrod mounting hole**



**Nose cabin door pushrod length**

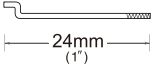

Pushrod diameter  $\varnothing 1.2\text{m}$

**Nose cabin door pushrod mounting hole**



**Rear cabin door pushrod length**

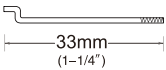

Pushrod diameter  $\varnothing 1.2\text{m}$

**Rear cabin door pushrod mounting hole**



**Rudder pushrod length**

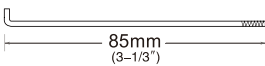

Pushrod diameter  $\varnothing 1.5\text{m}$

**Rudder pushrod mounting hole**



**Elevator pushrod length**

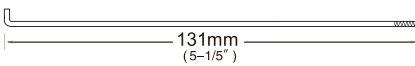

Pushrod diameter  $\varnothing 1.5\text{m}$

**Elevator pushrod mounting hole**



**Aileron pushrod length**

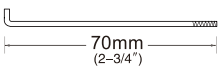

Pushrod diameter  $\varnothing 1.5\text{m}$

**Aileron pushrod mounting hole**



**Flap pushrod length**

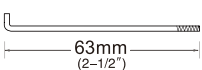

Pushrod diameter  $\varnothing 1.5\text{m}$

**Flap pushrod mounting hole**



**Center of Gravity**

Correct Center of Gravity ("CG") is critical for enabling safe aircraft stability and responsive control. Please refer to the following CG diagram to adjust your aircraft's Center of Gravity.

- Depending on the capacity and weight of your chosen flight batteries, move the battery forward or backward to adjust the Center of Gravity.
- If you cannot obtain the recommended CG by moving the battery to a suitable location, you can also install a counterweight to achieve correct CG. However, with the recommended battery size, a counterweight is not required. We recommend flying without unnecessary counterweight.

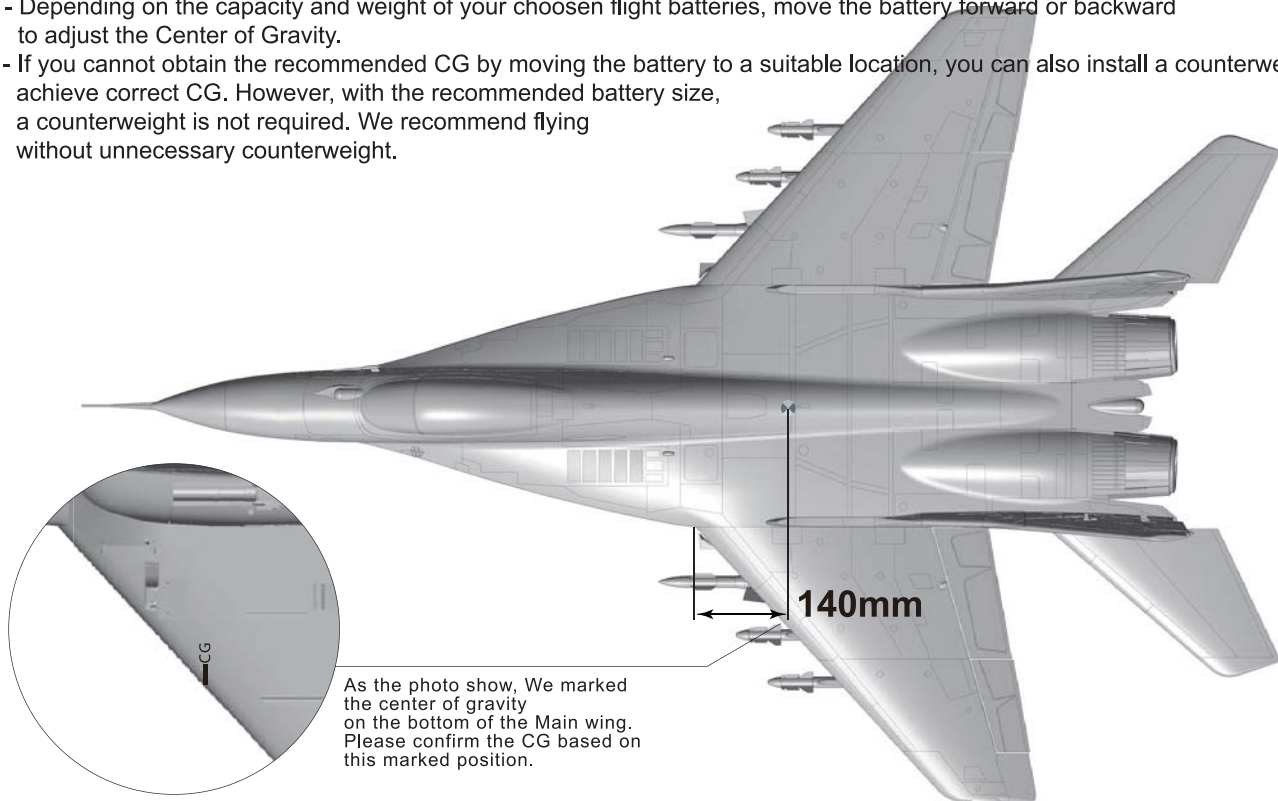

As the photo show, We marked the center of gravity on the bottom of the Main wing. Please confirm the CG based on this marked position.



**Control Direction Test**

After installed the plane, before flying, we need a fully charged battery and connect to the ESC, then use radio to test and check that every control surface work properly.

**Aileron**

Stick Left



Stick Right



**Rudder**

Stick Left

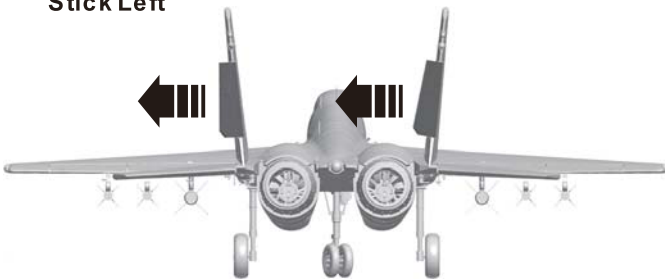

Stick Right

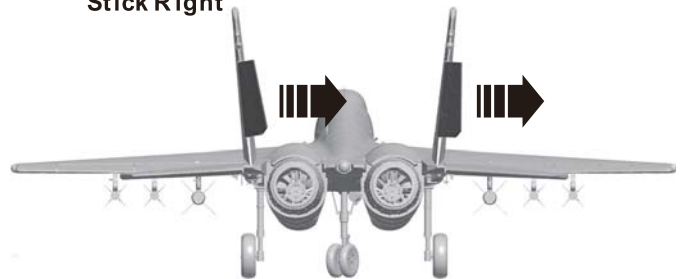

**Elevator**

Stick down



Stick up



**Flaps**

Flaps down

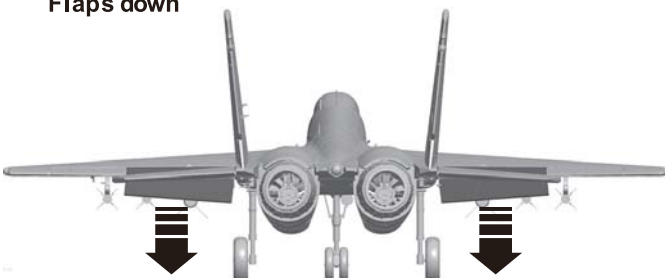

**Dual Rates**

According to our testing experience, use the following parameters to set Aileron/Elevator Rate. Program your preferred Exponential % in your radio transmitter. We recommend using High Rate for the first flight, and switching to Low Rate if you desire a lower sensitivity. On successive flights, adjust the Rates and Expo to suit your preference.

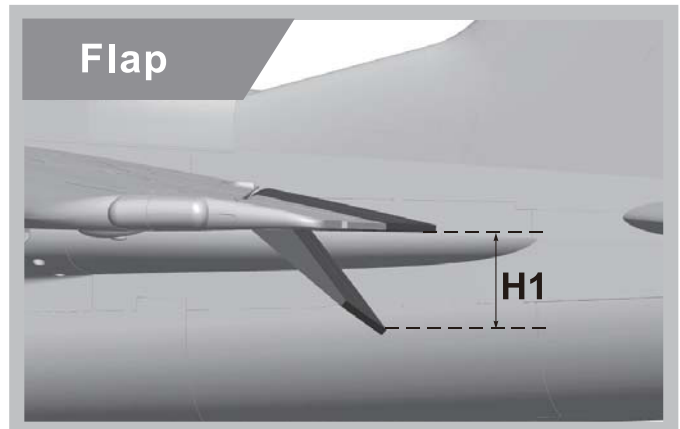
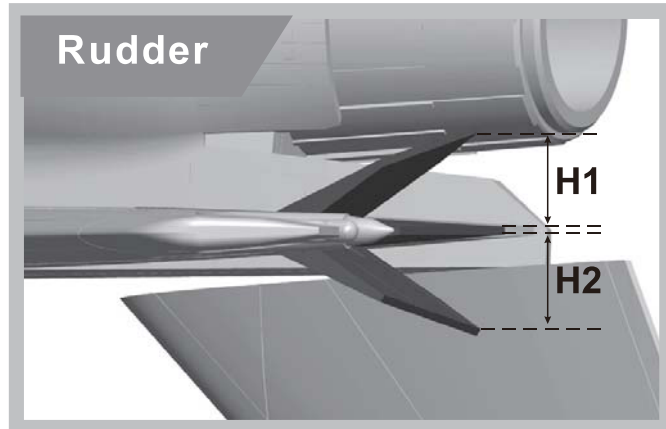
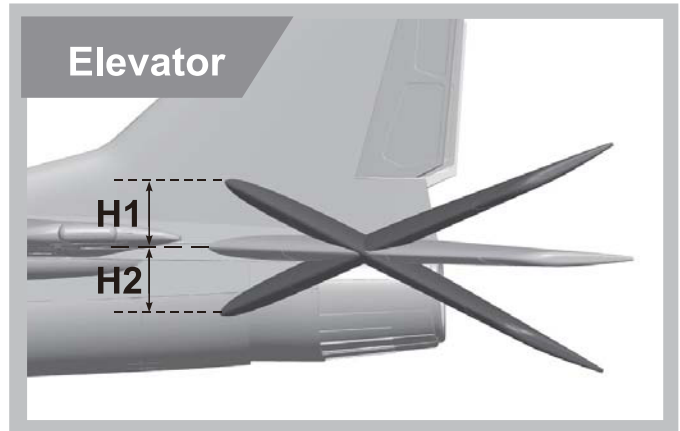
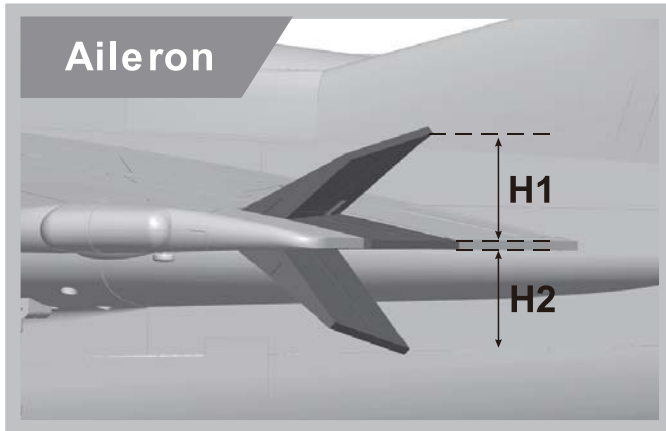

	<b>Aileron</b> (Measured closest to the fuselage)	<b>Elevator</b> (Measured closest to the fuselage)	<b>Rudder</b> (Measured from the bottom)	<b>Flaps</b>
<b>Low Rate</b>	H1/H2 38mm/38mm D/R Rate : 80%	H1/H2 34mm/34mm D/R Rate : 80%	H1/H2 38mm/38mm D/R Rate : 80%	H1 22mm
<b>High Rate</b>	H1/H2 43mm/43mm D/R Rate : 100%	H1/H2 39mm/39mm D/R Rate : 100%	H1/H2 45mm/45mm D/R Rate : 100%	H1 39mm

**The Elevator Center Position**

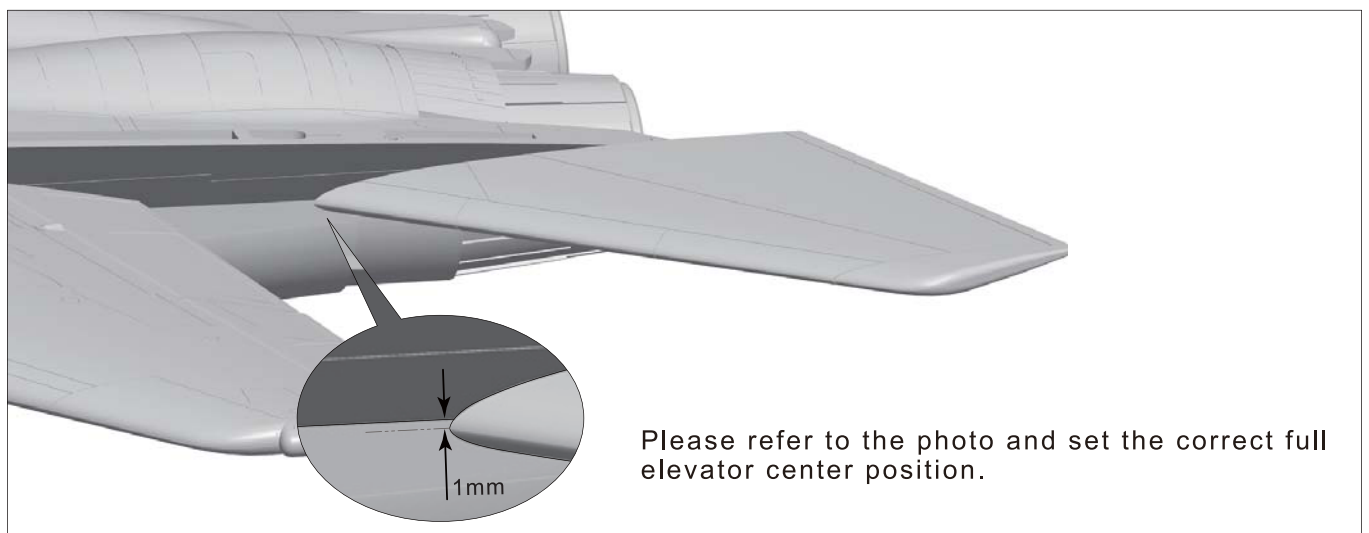

Please refer to the photo and set the correct full elevator center position.

Servo Direction

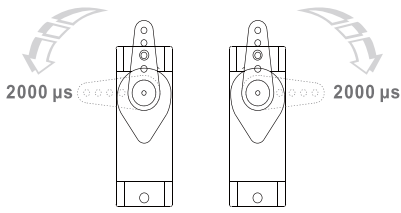

The servo positive or reverse rotation is defined as follows:  
 When servo input signal change from 1000μs to 2000μs,  
 The servo arm is rotated clockwise, its positive servo.  
 The servo arm is rotated counterclockwise, its reverse servo.

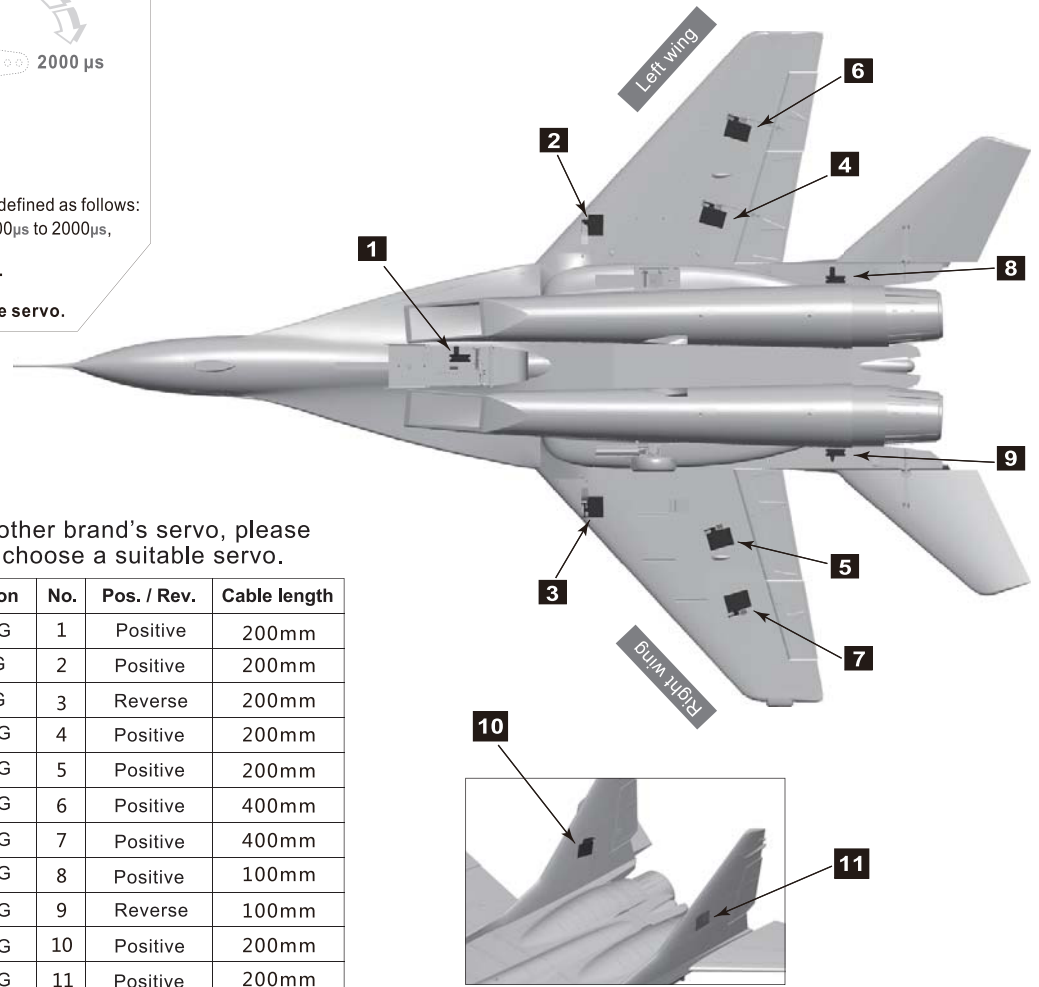

If you need to purchase another brand's servo, please refer to the following list to choose a suitable servo.

Position	Servo regulation	No.	Pos. / Rev.	Cable length
Nose gear steering servo	17g Digital-MG	1	Positive	200mm
Rear cabin door(L)	9g Digital-MG	2	Positive	200mm
Rear cabin door(R)	9g Digital-MG	3	Reverse	200mm
Flap(L)	17g Digital-MG	4	Positive	200mm
Flap(R)	17g Digital-MG	5	Positive	200mm
Aileron(L)	17g Digital-MG	6	Positive	400mm
Aileron(R)	17g Digital-MG	7	Positive	400mm
Elevator(L)	17g Digital-MG	8	Positive	100mm
Elevator(R)	17g Digital-MG	9	Reverse	100mm
Rudder(L)	17g Digital-MG	10	Positive	200mm
Rudder(R)	17g Digital-MG	11	Positive	200mm

Motor Specification

#MOI36584  
 3658-1920KV

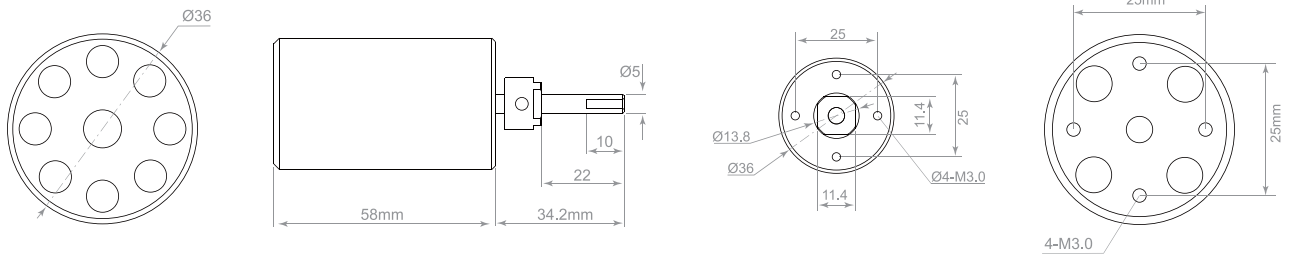

Unit: mm

Item No.	Fan size	Motor specifications	Voltage (V)	Current (A)	Max power (W)	Thrust (g)	Efficiency (g/w)	Speed (rpm)	Weight (g)
E72313	80mm 9-Blade	3658-1920KV	22.2	90	2000	3400	1.7	42000	345

